

# BATHROOM EXHAUST KITS

QUIET AND POWERFUL BATHROOM VENTILATION



Tel: 888-640-0925  
Fax: 513-268-4597

Sales@ventsus.com  
VentsUS.com  
400 Murray Rd,  
Cincinnati, OH 45217



## VENTS Bathroom Exhaust Kits

The ideal solution for simple exhaust ventilation without noise over your head

- Fans with 2 speed motor
- High airflow
- Easy mounting & cleaning
- Low noise
- Compact size

### Choose the right VENTS Kit:

The following recommendations are provided according to the guidelines of the Home Ventilating Institute (HVI):

### BATHROOM FAN SIZING GUIDELINE

$$S = W \times L$$

**(Bathroom area (sq. ft) = Length (ft) × Width (ft))**

#### If it's 100 sq. ft or smaller:

you need 1 CFM per 1 sq. ft

#### If it's over 100 sq. ft:

- airflow 50 CFM must be provided for each standard toilet, tub, shower or steam shower.
- airflow 100 CFM must be provided for each whirlpool, garden and hot tubs.

#### Example 1:

10' Length x 7' Width = 70 sq. ft of the bathroom area.  
You need a 70 CFM fan for this bathroom

#### Example 2:

1 Toilet +1 Shower +1 Whirlpool = 50 + 50 + 100 = 200 CFM

You will need a 200 CFM fan for this bathroom

## VENTS Bathroom Kit INSTALATION EXAMPLE

**VENTS Bathroom Kit** is the best way to arrange extract ventilation or replace an old noisy ceiling fan in your house. Installed away from the living space, VENTS bathroom kits offer powerful, yet silent ventilation solutions. Each kit consists of a plastic ceiling diffuser with the option of a built in LED light, a powerful inline fan, galvanized steel housing with damper and mounting brackets. VENTS offers kits for dual bathroom applications that features two galvanized steel housing with grille and a Y-Adapter.

### Bathroom air exhaust



Single ventilation kit installation



Dual ventilation kit installation

Tel: 888-640-0925  
Fax: 513-268-4597

Sales@ventsus.com  
VentsUS.com  
400 Murray Rd,  
Cincinnati, OH 45217



## Choose your kit

### TT SILENT KIT 100-1L



- TT Silent 100 (110 CFM)
- H-100L (LED light)

### TT SILENT KIT 150 DUO-2L



- TT Silent 150 (299 CFM)
- 2 H-100L (LED light)
- TMY 150/100 Zn

#### DIMENSIONS

Model	Measurements [in.]				lbs
	Ø D	B	H	L	
TT Silent 100	3 13/16"	7 11/16"	8 15/16"	11 15/16"	3.39
TT Silent 150	5 13/16"	8 11/16"	9 3/4"	11 3/8"	4.58

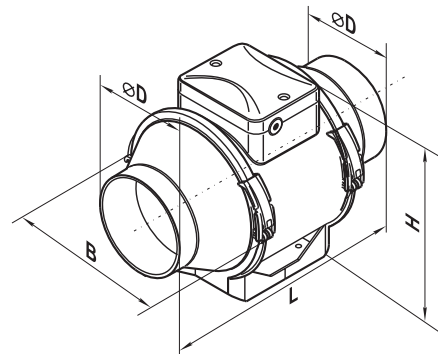

#### TT SILENT KITS PERFORMANCE

Model	Duct dia	Lamp	Ener-gyStar certified	Speed	RPM*	Sones	Watts*	Amps*	CFM vs. Static Pressure (Ps) in WG											Volts
									0	0.1	0.2	0.3	0.4	0.5	0.6	0.7	0.8	0.9	1	
TT Silent Kit 100-1	4"	1x7 W LED	yes	high	1994	1.5	30	0.25	146	128	110	88	64	44	21	9	-	-	-	120 V / 60 Hz
				low	1500	0.9	24	0.21	109	88	69	47	22	10	-	-	-	-	-	
TT Silent Kit 150 Duo-2L	4 1/6"	1x7 W LED	yes	high	2617	2.5	66	0.55	327	316	299	283	268	247	225	194	138	83	50	120 V / 60 Hz
				low	1933	1.1	52	0.45	240	219	194	171	134	111	86	57	27	7	-	

