



DESCRIPTION

VENTS' 120 S Energy Ventilator is a complete whole house ventilation system designed to bring a continuous supply of fresh air into the house while exhausting an equal amount of stale air. The unit can be mounted to the ceiling or to the wall with brackets.

Five year warranty.

CASING

Steel casing is covered with high-quality multilayer aluminium and zinc alloy to prevent corrosion.

The casing is equipped with a safety switch to turn the ventilator off when the service panel is opened.

AIR FILTRATION

Washable MERV6 air filters in exhaust and supply air streams.

DIMENSIONS

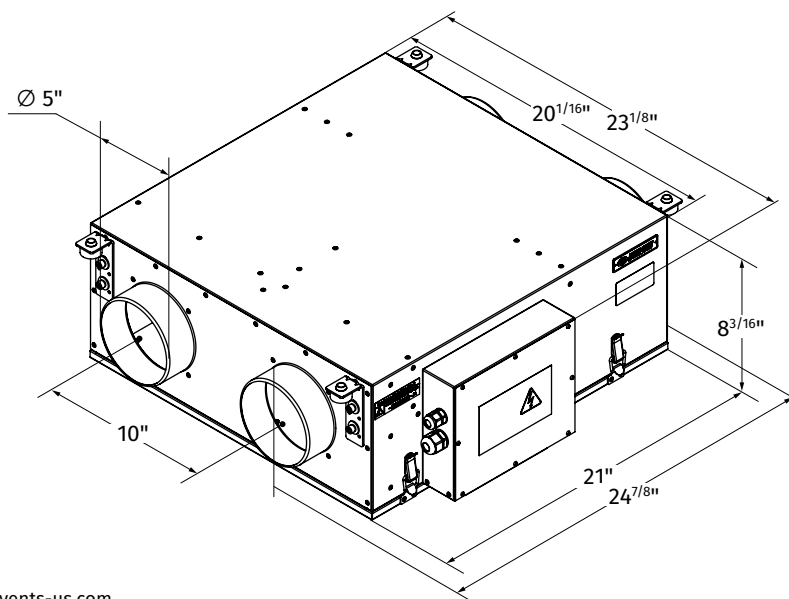

ENERGY RECOVERY CORE

Enthalpy ERV core, which ensures heat and moisture recovery.

DEFROST SYSTEM

To protect the Energy Recovery Core, an antifreeze electronic protection system is applied. It switches the supply fan off according to the temperature sensor settings. Warm extract air defrosts the ERV core then the supply fan switches on and the ventilator continues operating under rated conditions.

FANS

The unit is equipped with supply and exhaust centrifugal fans with backward curved blades and build-in thermal overheating protection with automatic restart. The electric motors and impellers are dynamically balanced.

CONTROL

Each unit is equipped with three-key speed switch to select LOW speed, MED speed or STANDBY mode for 24 hours operation. HIGH speed can be turned on/off with one of the optional remote controls.

SUITABLE FOR:

Bathroom / kitchen / apartments / cottages / small offices.



Frigate ERV 120 S

PRODUCT SPECIFICATIONS

TECHNICAL DATA

ENERGY RECOVERY VENTILATOR

PERFORMANCE

Model	ELECTRICAL REQUIREMENTS		EXHAUST AIR TRANSFER		EXT. STATIC PRESSURE		NET SUPPLY AIR FLOW	
	Volts	Amps	EAT @ 100Pa (%)	EAT @ 50Pa (%)	(Pa)	(in. wg)	(L/s)	(cfm)
ERV 120 S	120	1.5	6.6	5.7	25	0.1	52	110
					50	0.2	50	106
					75	0.3	47	100
					100	0.4	45	95
					125	0.5	43	92
					150	0.6	40	85
					175	0.7	38	80
					200	0.8	34	71
					225	0.9	29	62
					250	1	25	53
					275	1.1	21	44
					300	1.2	17	35
					325	1.3	12	26
					350	1.4	8	18
					375	1.5	4	9
400	1.6	0	0					

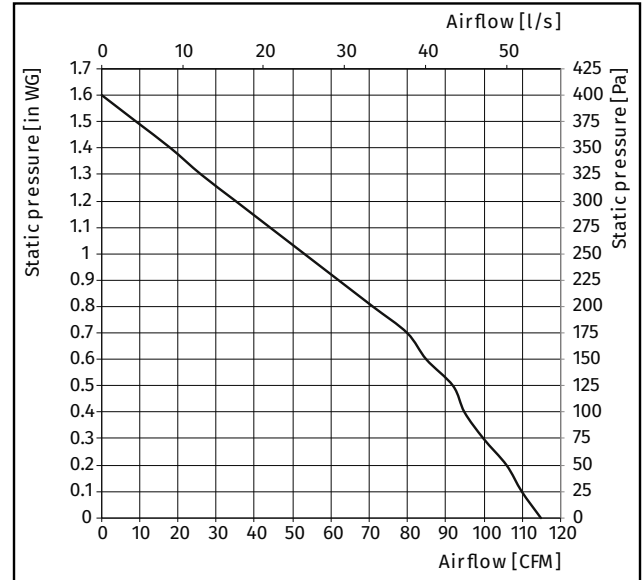

MODE	TEMPERATURE		NET AIR FLOW		POWER CONSUMED	SENSIBLE RECOVERY EFFICIENCY	APPARENT SENSIBLE EFFECTIVENESS	LATENT RECOVERY / MOISTURE TRANSFER
	°C	°F	(L/s)	(CFM)	(Watts)	SRE (%)	ASEF (%)	
HEATING	0	32	30	64	40	54	65	0.17
HEATING	0	32	45	95	62	49	59	0.12
HEATING	0	32	50	106	94	46	55	0.1

MODEL	QUANTITY	COMMENTS	PROJECT
			location:
			architect:
			engineer:
			contractor:
			submitted by:

Tel: 1-888-640-0925
513-583-5786

Sales@vents-us.com
Vents-US.com
400 Murray Road,
Cincinnati, OH 45217

