

# USER'S MANUAL

**Micra 150**



**HEAT RECOVERY UNIT**

## CONTENTS

Introduction	3
Use	3
Included in the Box	3
Designation Key Example	3
Technical data	3
Safety requirements	4
DESIGN AND OPERATION	5
Mounting and Installation Guidelines	6
Connection to Power Supply	8
Unit Control System	8
Maintenance	14
Troubleshooting	16
Storage and Transportation	16
Warranty	17

## INTRODUCTION

The present user manual consisting of technical details, operating instructions and technical specification covers the installation of the VENTS MICRA 150 heat recovery air handling unit, (hereinafter referred as the unit).

## USE

The unit is designed to save heat energy by means of heat recovery and is one of the energy saving components used in buildings and premises.

The unit is designed to provide permanent controllable air exchange by mechanical ventilation in houses, offices, hotels, cafés, meeting halls and other mechanically ventilated premises as well as utilization of extract air heat energy to warm up supply purified air.

The unit is rated for non-stop operation.

Transported air must not contain any flammable or explosive mixtures, evaporation of chemicals, coarse dust, soot and oil particles, sticky substances, fibrous materials, pathogens or any other harmful substances.



**INSTALLATION WORK AND ELECTRICAL WIRING MUST BE DONE BY QUALIFIED PERSON(S) IN ACCORDANCE WITH ALL APPLICABLE CODES AND STANDARDS.  
THE UNIT INSTALLATION SITES MUST PREVENT ACCESS BY UNATTENDED CHILDREN.**

## BOX INCLUDES:

- |   |   |
|---|---|
| <ul style="list-style-type: none"> <li>■ Unit</li> <li>■ Remote control</li> <li>■ User's manual</li> <li>■ Master plate</li> <li>■ Fasteners ( 8x80 expansion anchor and countersunk-headed screw)</li> <li>■ Packing box</li> </ul> | <ul style="list-style-type: none"> <li>- 1 item</li> <li>- 1 item</li> <li>- 1 item</li> <li>- 1 item</li> <li>- 4 items</li> <li>- 1 item</li> </ul> |
|---|---|

## DESIGNATION KEY EXAMPLE

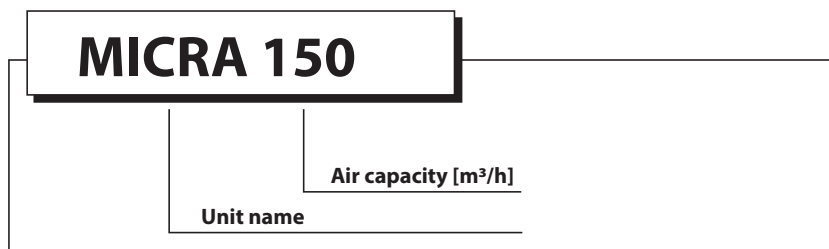

## TECHNICAL DATA

The unit is designed for indoor application with the ambient temperature ranging from +33.8 °F up to +104 °F and relative humidity up to 80 %.

Ingress Protection rating:

- IP44 for the unit motors;
- IP 22 for the assembled unit connected to air ducts.

The name designations, overall and connecting dimensions, outer view and technical data are shown in Fig. 1 and in Table 1.

The product design is periodically updated. Your unit may slightly differ from the model described here.

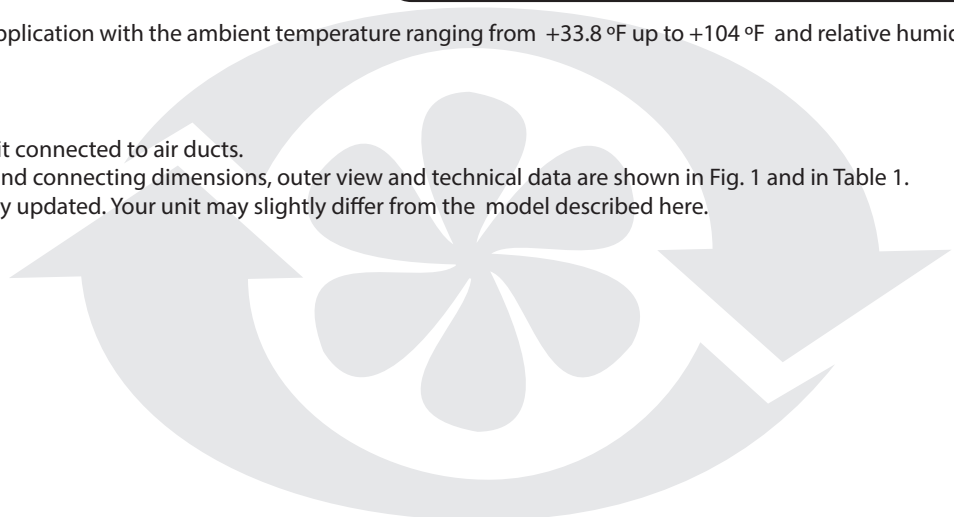

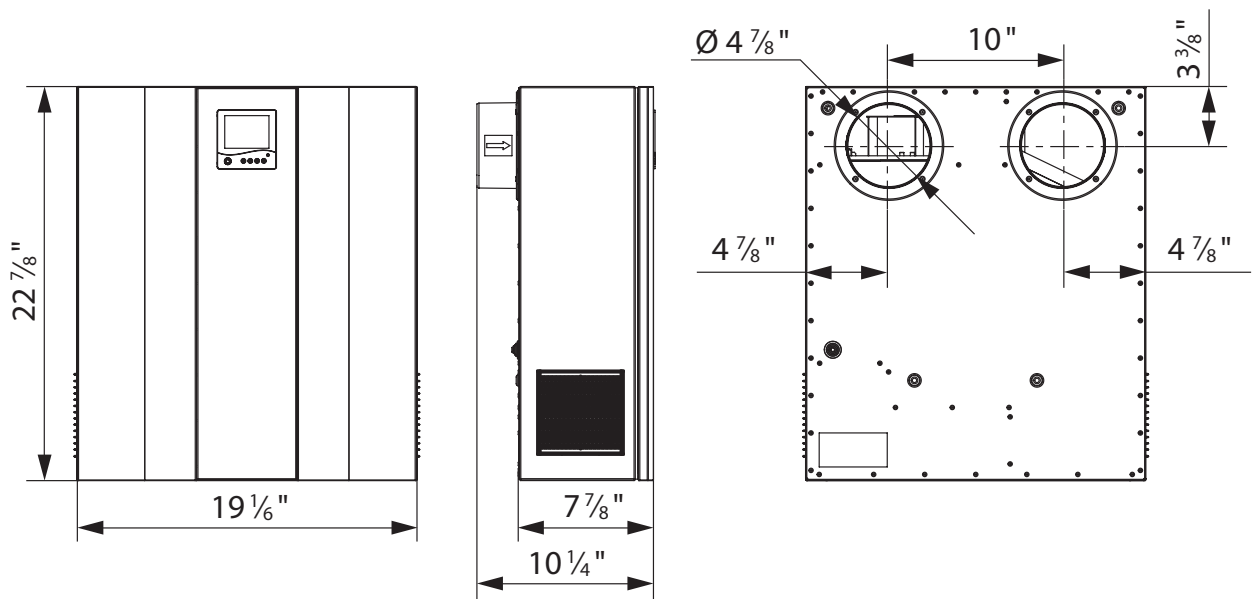

Fig. 1. Unit overall and connecting dimensions

Табл. 1 Технические параметры установки

Model	MICRA 150		
Ventilation mode	1	2	3
Voltage	120 V / 60 Hz		
Unit power without heating [W]	8	27	51
Unit max. current without heating [A]	0.7		
Air capacity [CFM]	35	53	71
RPM	450	780	2000
Noise level at 3 m distance [Sones]	1	1.3	1.8
Maximum transported air temperature [°F]	-13 ... +122		
Case material	polymer coated steel		
Heat insulation thickness [inch]	25/64"		
Filter: extract	MERV 5		
Filter: intake	MERV 7		
Replacement filter kit*	SF Micra 150		
Pipe diameter [inch]	5"		
Weight [lb]	44.09		
Sensible recovery efficiency (SRE) [%]	88	87	85
Heat exchanger type	counter-flow		
Heat exchanger material	polystyrene		

### SAFETY REQUIREMENTS

During installation and operation, observe all codes and safety standards for your locale.

Safe grounding must be provided!

Check the unit for possible damages prior to connecting it to power supply. Make sure the unit does not contain any foreign objects inside the case.



**WARNING!**  
WHENEVER THE HEAT RECOVERY UNIT IS INSTALLED, SERVICED, MOVED,  
OR REPAIRED IT MUST BE DISCONNECTED FROM THE MAIN POWER SOURCE.

**RESTRICTIONS!**

- UNDER NO CIRCUMSTANCES SHOULD THE UNIT BE OPERATED IN AN ENVIRONMENT WITH TEMPERATURES EXCEEDING THE TECHNICAL DATA INDICATED ON THE MOTOR NAME PLATE.
- DO NOT CONNECT A CLOTHES DRYER OR OTHER IRRELEVANT EQUIPMENT TO THE UNIT.

**DESIGN AND OPERATION**

Fig. 2. Design and operating logic





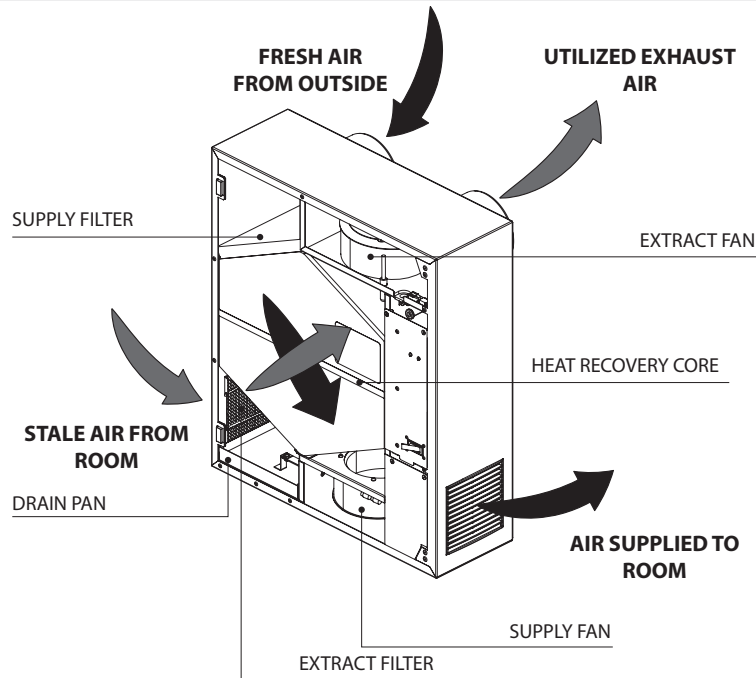
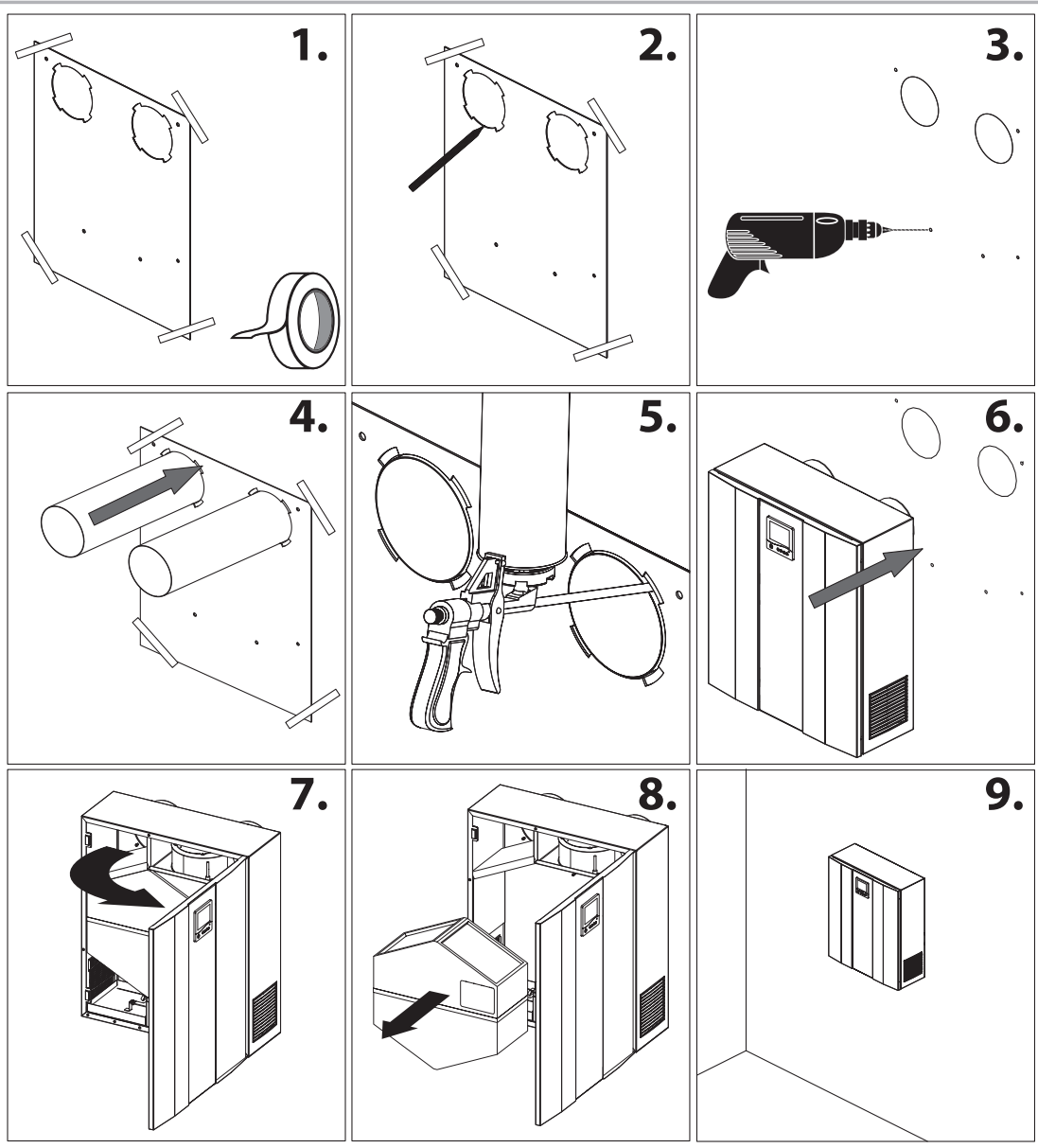

Fig. 5. Unit mounting using the master plate

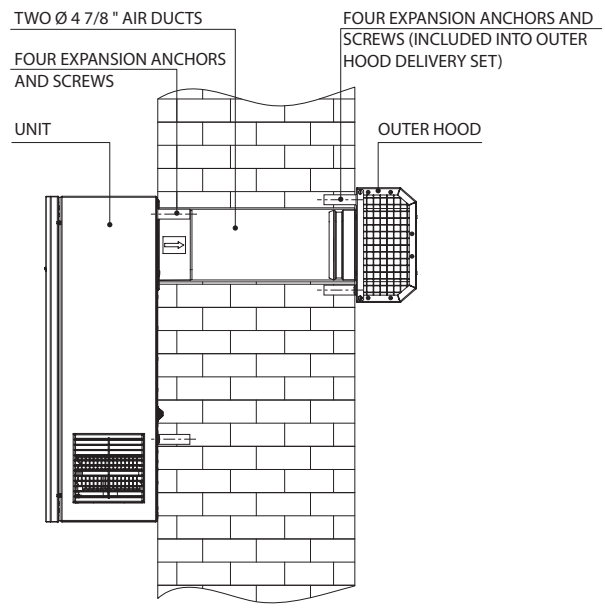

Fig. 6. Unit mounting

## CONNECTION TO POWER SUPPLY



**DISCONNECT THE UNIT FROM POWER SUPPLY BEFORE CONNECTION AND INSTALLATION OPERATIONS. ELECTRICAL WIRING SHOULD ONLY BE PERFORMED BY A QUALIFIED ELECTRICIAN. THE NOMINAL ELECTRIC PARAMETERS ARE SHOWN ON THE NAME PLATE. WARRANTY WILL NOT COVER EQUIPMENT DAMAGE OR FAILURE THAT IS CAUSED BY IMPROPER INSTALLATION.**

The unit is rated for connection to 120 V / 60 Hz power supply source. The unit is supplied with a pre-wired power cable and an adapter. It is suitable for connection to any standard grounded outlet compliant with IEC 60884-1. The power cable is pre-wired to the X1 terminal block, Fig. 7. The external power input must be equipped with a circuit breaker built into the stationary wiring to disconnect all the power mains phases. Install the circuit breaker to have a free quick access in case of need to turn the unit off promptly. The circuit breaker trip current must match the current consumption. The recommended circuit breaker rated current is 2.5 A. While selecting the automatic circuit breaker consider the maximum wire temperature that depends on the wire type, insulation, length and layout way (open wire mounting, channel type or wall-mounted).

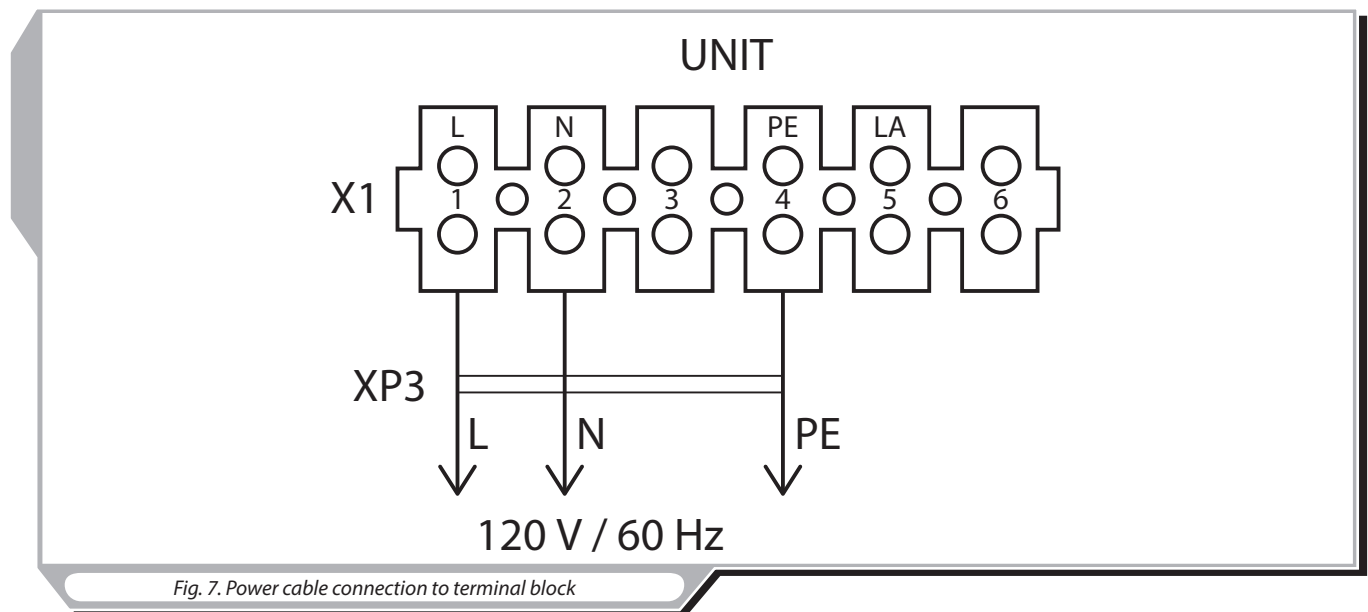

Fig. 7. Power cable connection to terminal block

## UNIT CONTROL SYSTEM

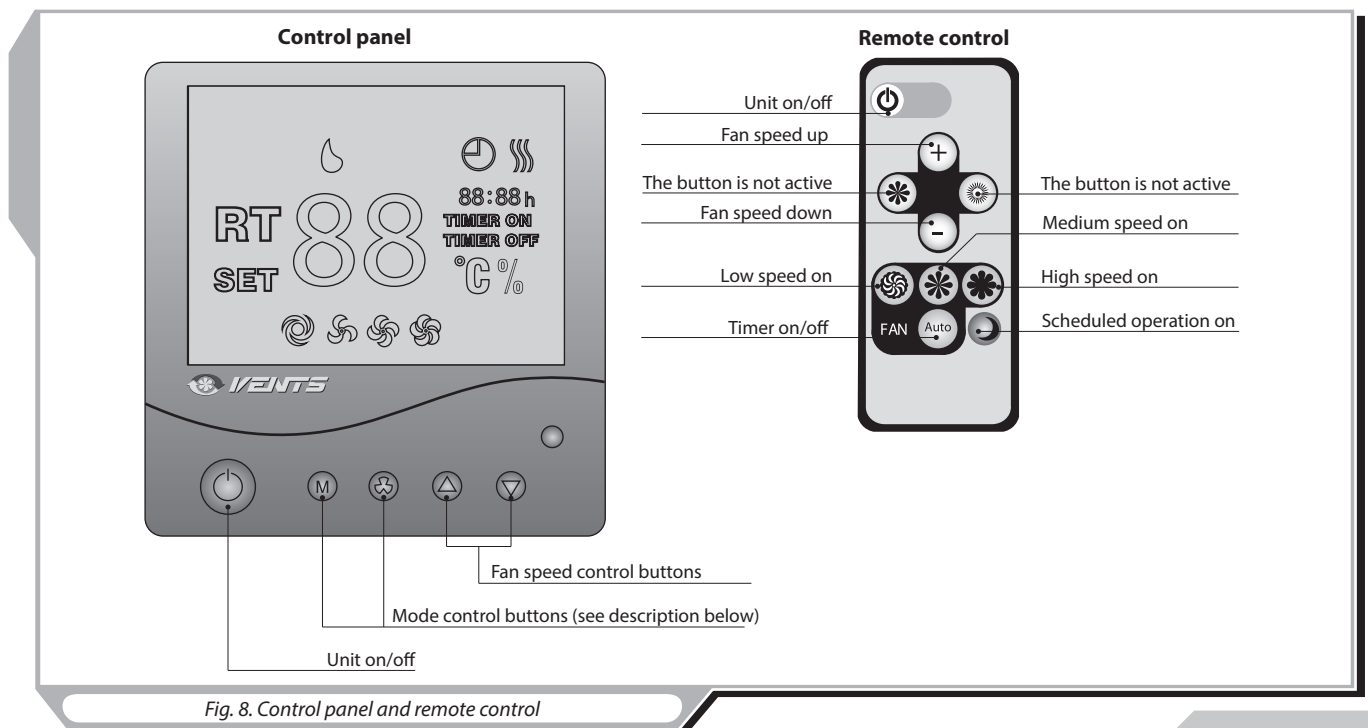



Fig. 8. Control panel and remote control



The unit is operated both from the control panel as well as from the remote control, Fig. 8.

### 1. Turning the unit ON / OFF.

To turn the unit ON / OFF:

- from the control panel: press ON/OFF button ;
- from the remote control: press ON/OFF button .

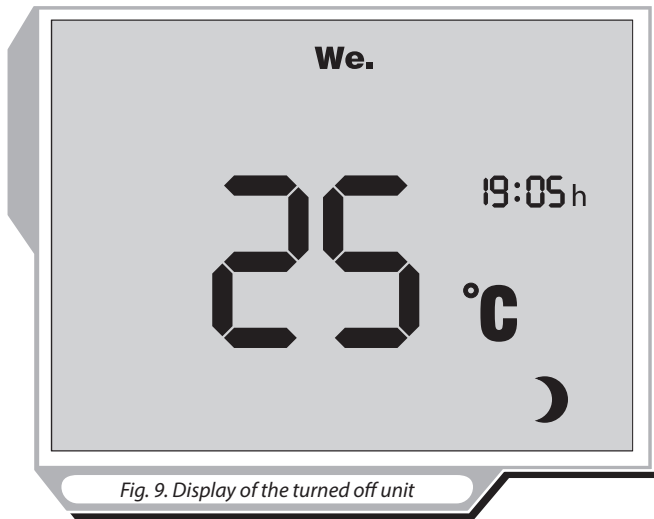



Fig. 9. Display of the turned off unit

The display shows the following indications as the unit is turned off, Fig. 9:

- Indoor temperature;
- Weekday;
- Time;
- OFF indication .

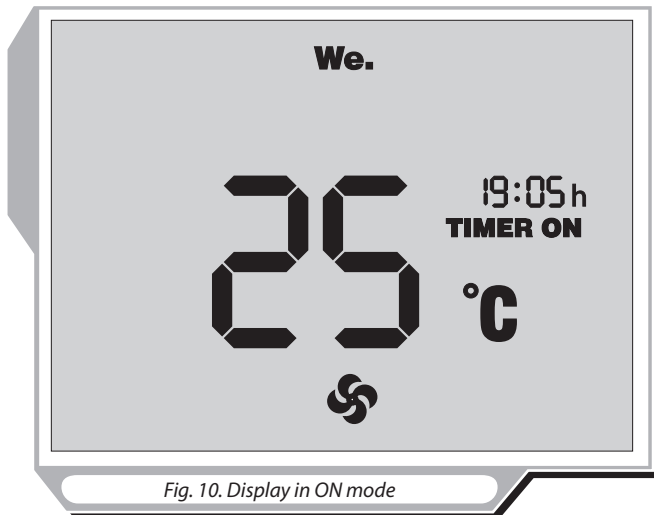









Fig. 10. Display in ON mode

The control panel displays the following indications as the unit is turned on, Fig. 10:



- Indoor temperature;
- Weekday;
- Time;
- Fan speed indicator ;
- Timer status information.
  - The **TIMER ON** indicator is displayed as the timer is turned on.
  - The **TIMER OFF** indicator is displayed as the timer is turned off.

### 2. Unit ventilation mode control.

Unit fan speed operation:

- Control panel: press  for setting speed up or  for setting speed down (low speed - medium speed - high speed);
- Remote control: press  for setting speed up or  for setting speed down (low speed - medium speed - high speed);
- Remote control: press  to activate low speed,  to activate medium speed and  to activate high speed modes.

The control panel displays the current fan speed:

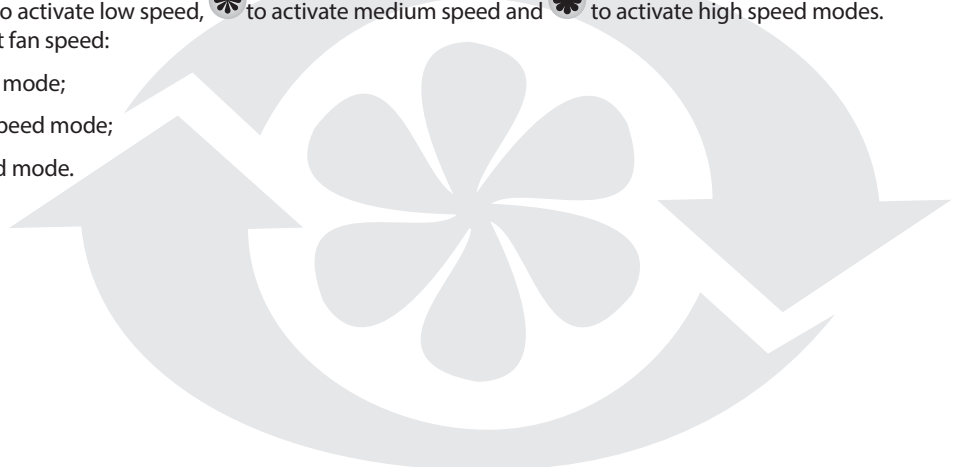

- Indicator  — low speed mode;
- Indicator  — medium speed mode;
- Indicator  — high speed mode.









### 3. Timer.

The timer switches the fans to the high speed with subsequent automatic reset to a previous speed after a set time period, from 20 to 60 minutes.

Turning the timer on/off:

- from the control panel: press and hold , then press . Press the button once to set the timer for 20 minutes, each subsequent pressing extends the timer setting for 10 minutes. The maximum timer setting is 60 minutes. Press and hold the  button for 3 seconds to turn the timer off;

- с пульта дистанционного управления: для включения таймера на 20 минут нажмите кнопку . Для отключения таймера выключите установку кнопкой  или .

- from the remote control: press  to turn the timer on for 20 minutes. To turn the timer off press  or .

### 4. Freeze protection for the heat recovery core.



If exhaust air temperature downstream of the heat recovery core is below +37.4 °F, the supply fan is turned off. If supply air temperature rises above +37.4 °F, the unit reverts to the set operating mode.

### 5. Unit Parameter Setting.



**RE-ADJUSTMENT OF THE UNIT SETTINGS RESULTS IN LOSS OF THE FACTORY SETTINGS! FAN SPEED AND TEMPERATURE SENSOR SETTING IS POSSIBLE ONLY FROM THE CONTROL PANEL!**

#### Fan speed setting mode.

The capacity of low, medium and high speeds are adjustable. To enter the fan speed setting mode, turn the unit off. Then press and hold  button on the control panel and hold  pressed for 3 seconds.

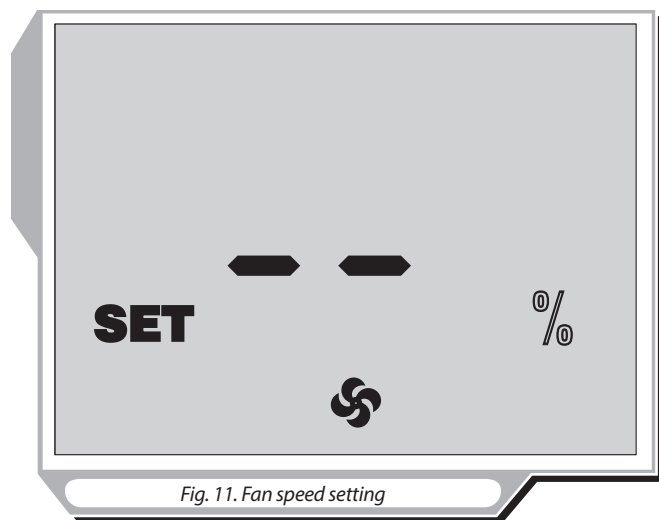







Fig. 11. Fan speed setting



После входа в режим настройки на дисплее панели управления отображается индикатор **SET** и **%** (рис. 11).







- Выбор необходимой настраиваемой скорости осуществляется кнопками  и .







При выборе настраиваемой скорости на дисплее будет отображаться индикация выбранной скорости ,  или .

Access to the setting mode is confirmed by **SET** and **%** indicators on the control panel display, Fig. 11.

To select the required speed use  or .

While selecting the required speed the ,  or  indications are displayed.

- To adjust the supply fan capacity press and hold , then press  to set the fan speed up or  to set the fan speed down. Each pressing of  and  buttons increases or decreases the supply fan speed by 1%. While holding  button the display indicators show the current supply fan speed, Fig. 12.

- To adjust the extract fan speed press and hold  and regulate the speed using  for setting the speed up or  for setting speed down. Each pressing of  and  buttons increases or decreases the extract fan speed by 1%. While holding  button the display indicators show the current extract fan speed.

To exit the fan speed setting mode and save changes press .

Fan speed adjustment is not possible via the remote control.

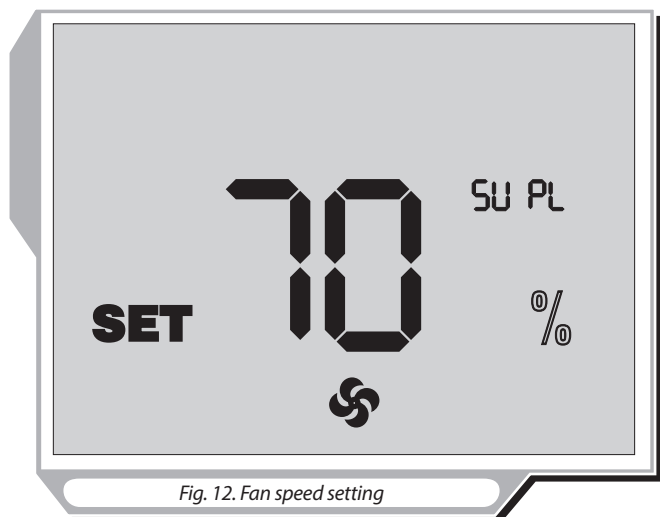

Fig. 12. Fan speed setting

To reset the unit to the factory settings, enter the fan speed setting mode, synchronously press and hold (▲) and (▼) buttons for 3 seconds.

Fan speed factory settings:

- low speed — 40 %
- medium speed — 70 %
- high speed — 100 %

## 6. Filter replacement signal.

As the filter service life expires (3000 hours) the control panel displays a filter replacement indicator **F** instead of the operating temperature, Fig. 13.

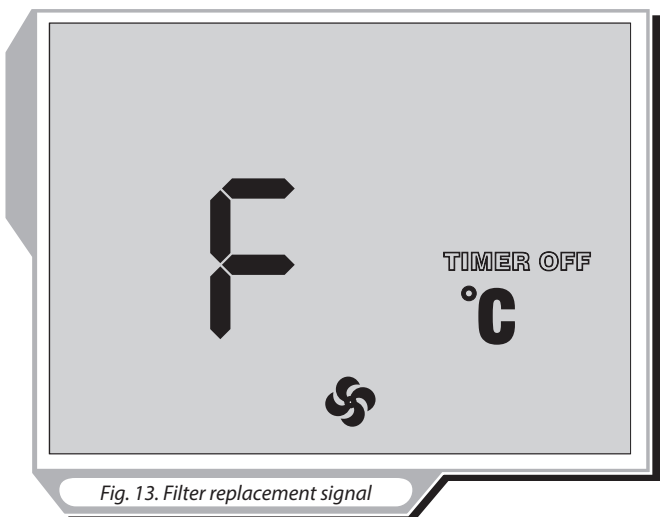

Fig. 13. Filter replacement signal

- In case of the filter replacement signal **F** turn the unit off by pressing (⏻) and disconnect it from power supply. Then replace the filters following the filter replacement procedure in the "Maintenance" section, page 14.

- After that press (⏻) on the control panel or (⏻) on the remote control to turn the unit on. Then press synchronously (▲) and (▼) buttons to reset the operating hours of the motor.

## 7. Date and time setting.

- Turn the unit off.
- Press and hold (M), then press (▲) on the control panel to enter the date and time setting mode.
- Hold (M) button and select a parameter to be edited using (▲) and (▼) buttons. An editable parameter blinks.

The date and time setting parameters are located as listed:

1. Minutes;
2. Hours;
3. Weekday;
4. Date;
5. Month;
6. Year.





- Then set the required parameter using (▲) or (▼) buttons on the control panel.
- Press (⏻) to exit the date and time setting mode.

## 8. Time scheduled operation.

- Press and hold (⌚), then press (▲) on the control panel to activate the time-scheduled operation. The (⌚) indicator confirms that the time-scheduled operation of the unit is activated.
- Press and hold (⌚), then press (▼) on the control panel to deactivate the time-scheduled operation.
- Press (⏻) on the remote control to activate or deactivate the unit time-scheduled operation.
- The timer control has higher priority than the time-scheduled operation.

### 9. Time-scheduled operation setting.

Each weekday has four entries that determine the fan switching to the set fan speed.

- To enter the time-scheduled operation setting mode, turn the unit off with the  button on the control panel or with the  button on the remote control.
- Press and hold  on the control panel and the press .

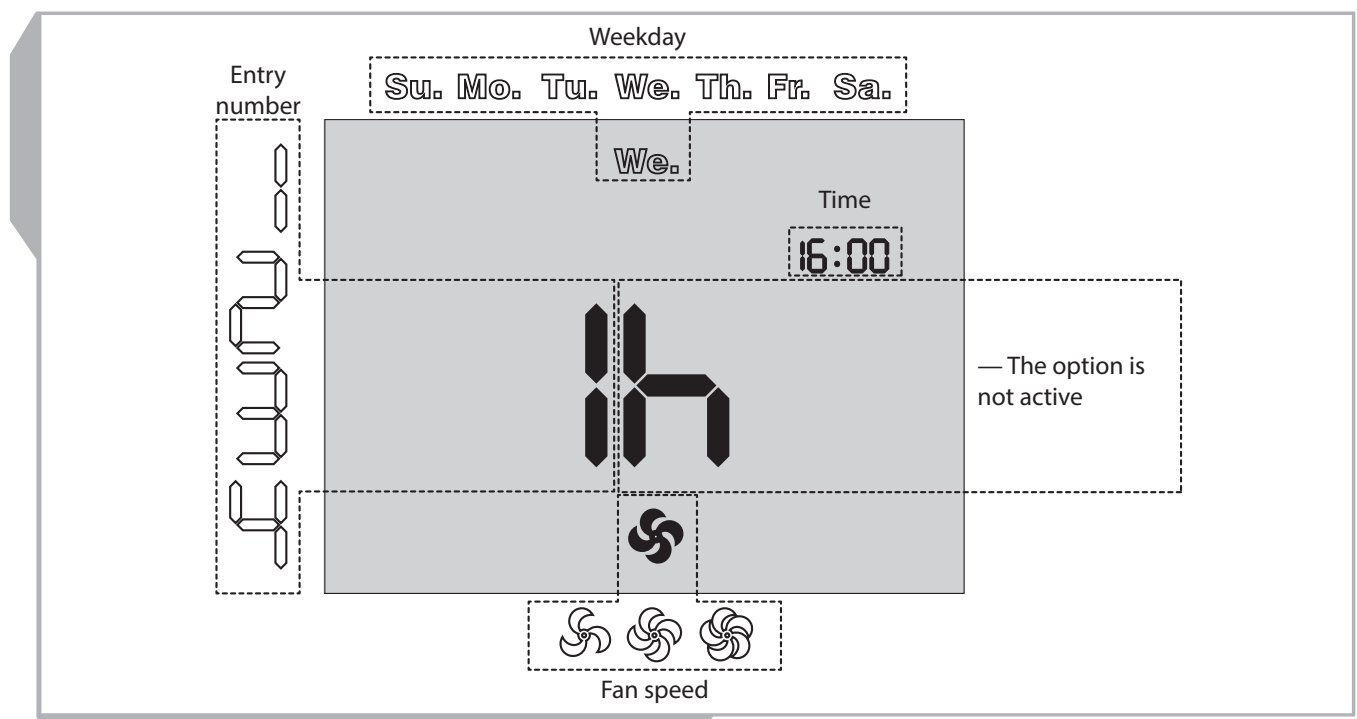

Fig. 14. Time-scheduled operation indicators











- Hold  and select a required parameter to be adjusted using  or  buttons.
  - Set a required parameter using  or  buttons.
- Time-scheduled operation parameters, Fig. 14:
- Entry number - each weekday has four entries.
  - Weekday - setting of a weekday.
  - Fan speed - setting of the fan speed for the current entry.
  - Time - time setting for the current entry.
- To copy the set entries for the next day press and hold  and press . No copying from Sunday to Monday is possible.
  - Для выхода из режима настройки расписания нажмите кнопку  на панели управления или кнопку  на пульте дистанционного управления.
  - Press  on the control panel or  on the remote control to exit the time-scheduled operation setting mode.
- The example of the time-scheduled operation programming is stated in Table 2.

Table 2. Example of programming

Weekday	Entry number							
	1		2		3		4	
	Start time	Mode	Start time	Mode	Start time	Mode	Start time	Mode
Mo.	07:00	2 speed	08:00	1 speed	17:00	2 speed	22:00	1 speed
Tu.	07:00	2 speed	08:00	1 speed	17:00	2 speed	22:00	1 speed
We.	07:00	2 speed	08:00	1 speed	17:00	2 speed	22:00	1 speed
Th.	07:00	2 speed	08:00	1 speed	17:00	2 speed	22:00	1 speed
Fr.	07:00	2 speed	08:00	1 speed	17:00	2 speed	22:00	1 speed
Sa.	10:00	2 speed	12:00	2 speed	17:00	2 speed	23:00	1 speed
Su.	10:00	2 speed	12:00	2 speed	17:00	2 speed	23:00	1 speed

### 10. Alarms.

In case of alarm the unit is turned off and the control panel displays the alarm indicators, Fig. 15. The possible alarms are listed in Table 3.

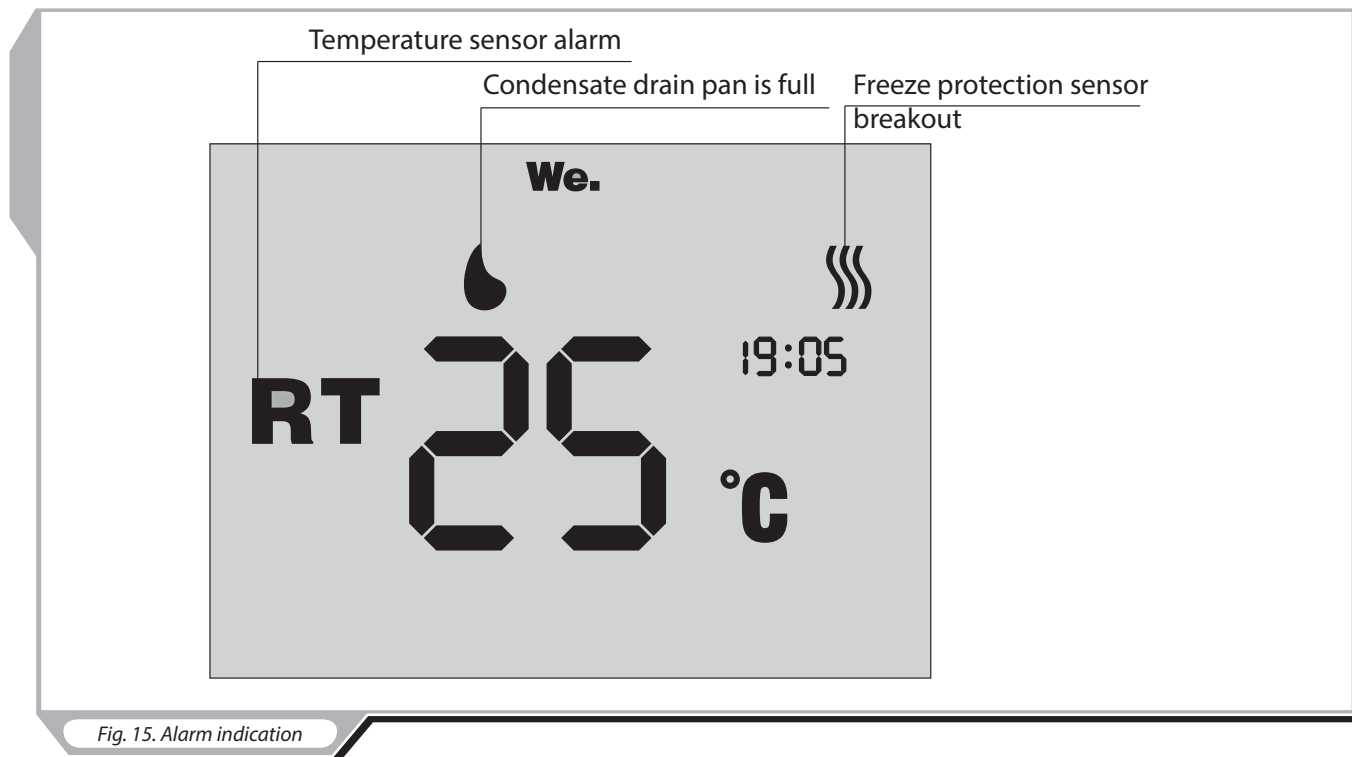



Fig. 15. Alarm indication

Table 3. Unit alarms

ALARM	INDICATION	FAULT HANDLING
Temperature sensor alarm	<b>RT</b>	Contact the Seller for servicing.
Duct temperature sensor breakout	<b>RT</b> 	Contact the Seller to troubleshoot the freeze protection temperature sensor.
Condensate drain pan is full		Follow the servicing sequence in the "Maintenance" section, page 14.



## MAINTENANCE

Regular maintenance should be performed every 3 months as follows:

### 1. Filter inspection (3-4 times per year).

Dirty filters increase air resistance and reduce supplied air volume to the room. Clean the filters as often as required, but at least 3-4 times per year. Cleaning with a vacuum cleaner is allowed. After two consecutive cleanings filters must be replaced. Contact the unit Seller to purchase new filters.

Filter removal as in Fig. 16:

1. Open the unit access door.
2. Remove the supply air filter installed above the heat recovery core;
3. Pull the band to withdraw the heat recovery core from the unit;
4. Press the clamp and remove it;
5. Remove the extract air filter.

Install the filters in the reverse order.

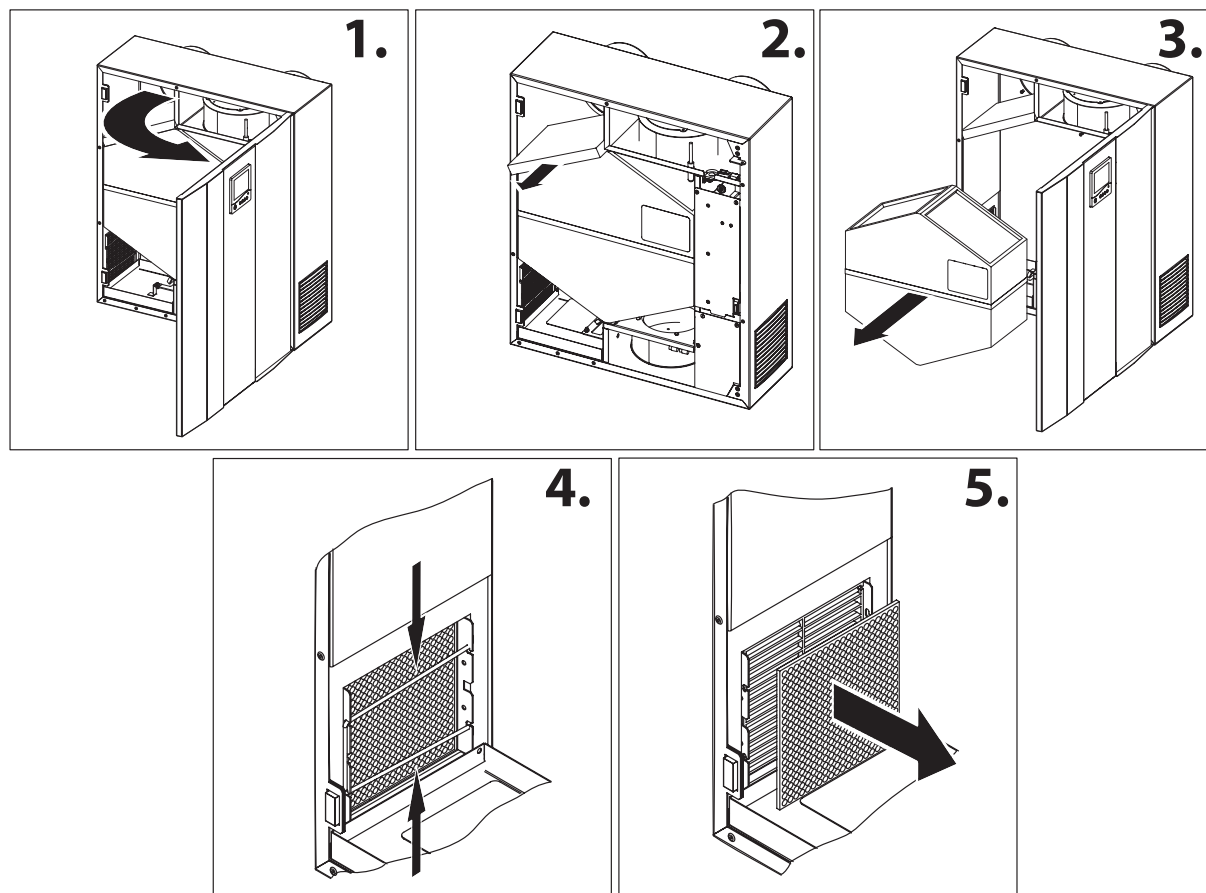

Fig. 16. Filter maintenance

### 2. Heat recovery core inspection (once per year).

The regular filter maintenance may not completely prevent dust ingress into the heat recovery core. The heat recovery core must be regularly cleaned to maintain high heat recovery efficiency. Remove the heat recovery core from the unit and wash it with soap water. Let the heat recovery core dry and re-install it into the unit.

### 3. Fan inspection (once per year).

Regular filter and heat recovery core maintenance may not completely prevent dust ingress into the unit fans. Clogged filter reduce supplied air volume to the room.

Clean the fans with a soft cloth or a brush. No water and abrasive detergent, sharp objects or solvents are allowed for cleaning to prevent the impeller damage.

#### 4. Condensate removal (as required).

The drain line may get clogged by extracted particles. As the drain pan gets filled with condensate, the unit turns off and the control panel displays the  indicator to remind about the need to remove the condensate.

To remove condensate:

1. Disconnect the unit from power supply.
2. Open the unit door.
3. Lift the condensate level switch.
4. Holding the condensate level switch, pull and remove the condensate drain pan carefully, Fig. 17.

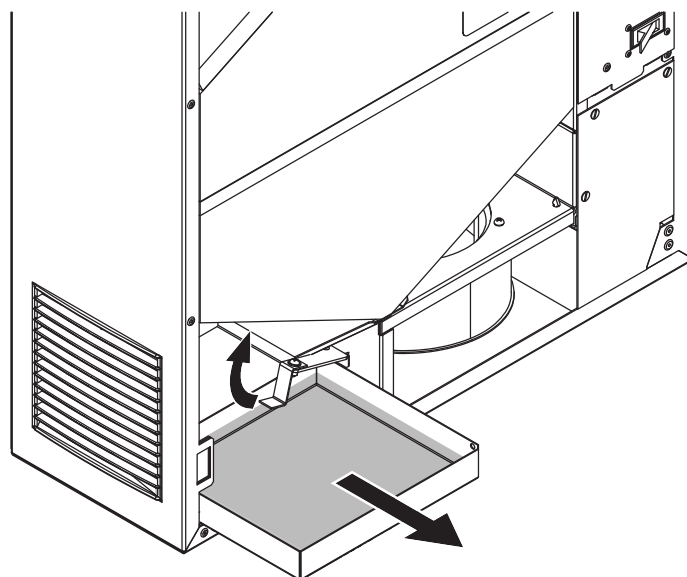

Fig. 17. Drain pan removing

5. Empty the drain pan, lift the condensate level switch and reinstall the drain pan back, Fig. 18.

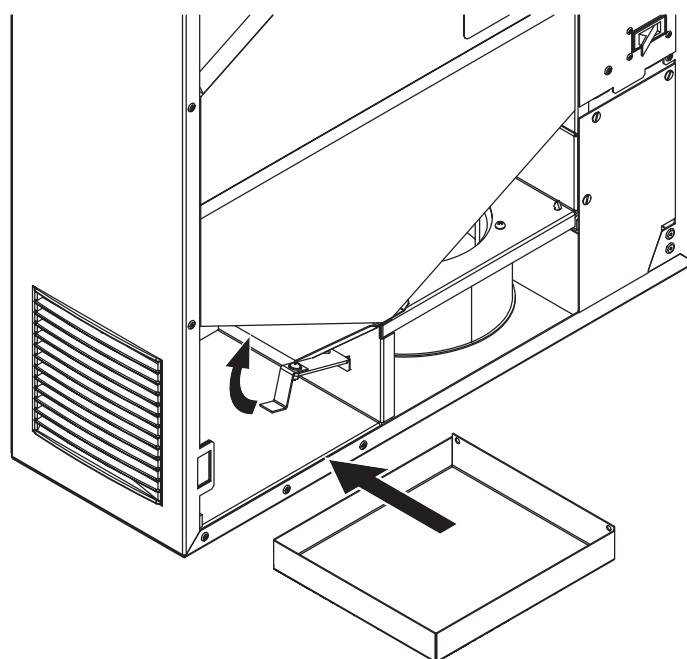

Fig. 18. Drain pan installation

#### 5. Intake inspection (twice per year).

The intake grille may get clogged with leaves and other outdoor pollutants. Check the intake grille twice per year and clean as required.

#### 6. Air ductwork maintenance (once in 5 years).

If degraded performance is still noticeable after following all maintenance guidelines it is recommended that the ductwork be checked and cleaned if necessary.

## TROUBLESHOOTING

### Possible faults and fault handling

Problem	Probable reason	Troubleshooting
The fan(s) do not get started	No power supply	Make sure the power supply line is connected correctly, otherwise troubleshoot the connection error.
Cold supply air	Dirty extract filter	Clean or replace the extract filter.
	Heat recovery core freezing	Check the heat recovery core for icing. Shut the unit off if required and turn it on after the freezing danger is no longer imminent.
Low set air flow	Dirty filters, impellers, heat recovery core	Clean or replace the filters; clean the fans and the heat recovery core.
	Dirty or damaged ventilation system	Check opening of the diffusers and louvre shutters, check the extract hood and supply grille and clean it if required; make sure the air ducts are not soiled and not damaged.
Noise, vibration	Dirty impeller	Clean the fan impeller.
	Loose screw	Tighten the screws to stop.
Condensate leakage	The condensate level switch malfunction.	Please contact your Seller for servicing.

## STORAGE AND TRANSPORTATION

Risk of injury when lifting and installing the unit. Get a helper and wear eye protection. Keep the unit in a dry, weather protected premise in the manufacturer's original packing box in a clean environment.

Protect the unit against possible harmful environmental impact until it is finally mounted. We do not recommend storing of the unit longer than one year.

Keep the duly temperature and humidity conditions in the stock environment.

Connection of the unit to power mains is allowed only in 2 hours since its keeping in an premise with the room temperature.

Avoid any mechanical shocks and strokes during handling operations.



## WARRANTY

VENTS US warrants to the original purchaser of the Micra 150 unit that it will be free from defects in materials or workmanship for a period of 60 months from the date of original purchase. The VENTS US warrants to the original purchaser of the Micra 150 unit that the integrated control unit will be free from defects in materials and workmanship for a period of 24 months from the date of original purchase.



**THERE ARE NO OTHER WARRANTIES, EXPRESS OR IMPLIED, INCLUDING, BUT NOT LIMITED TO, IMPLIED WARRANTIES OF MERCHANTABILITY OR FITNESS FOR A PARTICULAR PURPOSE.**

During the stated warranty period, VENTS US will, at its option, repair or replace, without charge, any product or part which is found to be defective under normal use and service. This warranty does not cover (a) normal maintenance and normal service or (b) any products or parts which have been subject to misuse, negligence, accident, improper maintenance or repair (other than by VENTS US), faulty installation or installation contrary to recommended installation instructions. Labor to remove and replace products is not covered.

The duration of any implied warranty is limited to the time period specified for the express warranty. Some states do not allow limitations on how long an implied warranty lasts, so the above limitation may not apply to you.

VENTS US OBLIGATION TO REPAIR OR REPLACE, AT VENTS US OPTION, SHALL BE THE PURCHASER'S SOLE AND EXCLUSIVE REMEDY UNDER THIS WARRANTY. VENTS US SHALL NOT BE LIABLE FOR INCIDENTAL, CONSEQUENTIAL OR SPECIAL DAMAGES ARISING OUT OF OR IN CONNECTION WITH PRODUCT USE OR PERFORMANCE.

Some states do not allow the exclusion or limitations of incidental or consequential damages, so the above limitation or exclusion may not apply to you. This warranty gives you specific legal rights, and you may also have other rights which vary from state to state. This warranty supersedes all prior warranties.

If proof of sales date is absent, warranty period is calculated from the production date.

The unit can be exchanged at the following address:

Bodor Vents, LLC DBA: Vents-US

11013 Kenwood Road Cincinnati, Ohio 45242

Phone: (513)348-3853

e-mail: sales@ventsus.com



**PLEASE FOLLOW GUIDELINES IN THIS MANUAL FOR PRODUCT PROBLEM-FREE OPERATION.**





