



### DESCRIPTION

The wall vent is an air handling unit designed for creation of a continuous air exchange and supply of fresh air to residential and non-residential premises. PSS is a cost-efficient and autonomous device for more intensive air exchange as compared to passive airing. The vent PSS allows bringing fresh air inside without opening the windows and thus without letting the dust, street noise and plant pollen enter the room. Specially developed design of inner grille, as well as the device for controlling the open cross-section of the inflow, provide for a steady inflow and uniform distribution of fresh air in the room. The vent is installed on the sunny side of the outer wall of an apartment, cottage, office building, etc.

### FEATURES

1. Suitable for air handling of small and middle-size premises (depending on the way of installation of the fan). The air flow direction can be easily changed by turning the motor 180 degrees;
2. The solar panel provides for a more intensive air exchange as compared to regular passive airing;
3. Cost efficiency: the natural solar power is used;
4. Independence: the motor is powered by solar panel. Supply voltage of the motor is 9...18 V. Electric parameters of the solar panel change depending on intensity of the solar flux. Intermediary parameters are shown in the table below;
5. In dark hours of the day, the ventilator operates as an element of passive ventilation;
6. Possibility to manually control the cross-section of the air flow.

### DESIGN

Wall vent consists of two ventilation grills (inside and external) and a telescopic air duct.

The inner grill is produced from high-quality ABS plastic and is equipped with a dust filter. Inside the grille, a small motor is installed for intake or exhaust of air. The direction of air flow can be easily reversed by turning the motor 180°. The built-in control device allows to vary the volume of the inflowing air or to fully close the ventilation channel.

The length of the telescopic PVC air duct can be adjusted.

The external grill (ventilation cowl) is produced from high-quality ABS plastic. The solar panel which supplies power to the motor is mounted on the ventilation cap's surface.

### AIR FLOW DISTRIBUTION

The design of the inner grill, as well as the device for controlling the open cross-section of the air flow, provide for a steady inflow and uniform distribution of fresh air in the room. Depending on the desirable inflow rate, you can smoothly control the intensity of air inflow.

**PERFORMANCE**

Voltage, V	Consumption current, A	r.p.m.	Air flow capacity, CFM
9	0,064	1390	8
12	0,073	1754	9
15	0,083	2140	10
18	0,092	2490	12

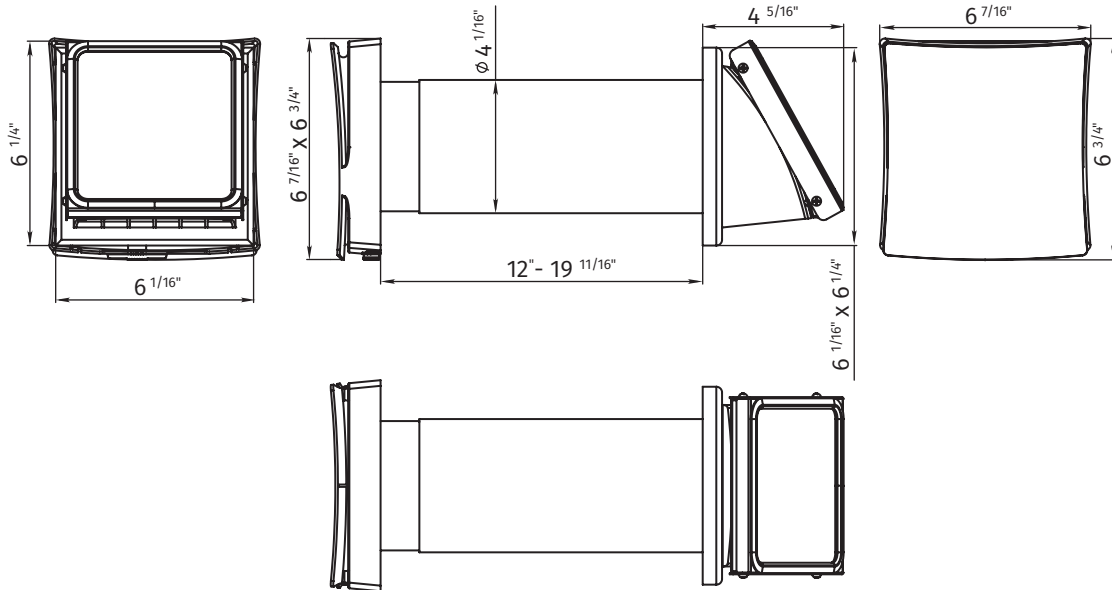
**DIMENSIONS**

MODEL	QUANTITY	COMMENTS	PROJECT
			location:
			architect:
			engineer:
			contractor:
			submitted by:

 Tel: 888-640-0925  
 Fax: 513-268-4597

 Sales@ventsus.com  
 VentsUS.com  
 400 Murray Rd,  
 Cincinnati, OH 45217

**HARDI**