



DESCRIPTION

Turbo Tube PRO series is the new ideal engineering solution for premises where powerful airflow is required. The unique motor, powerful mixed flow impeller and special aerodynamic casing combination enables the Turbo Tube PRO fans to deliver superb airflow performance even at higher static pressures typically found in extensive ventilation systems. The Removable Body, including motor, impeller and junction box, is the Ultimate Solution for Easy Installation & cleaning. Turbo Tube PRO fans are compatible with 4", 5", 6" diameter ducts.

CASING

The fan's casing is made of high quality, UV resistant plastic (UL94 certified plastic). It is equipped with a mounting plate to attach the fan to the wall or ceiling.

MOTOR

Motors are supplied with automatic reset thermal protection and are equipped with ball bearings for longer service life (40,000 hrs). Suitable for air stream temperature up to 140 °F.

SUITABLE FOR:

Kitchen / pools / stores / bars / restaurants / offices / public institutions / manufactures etc

DIMENSIONS

Model	Measurements [in.]					lbs
	ØD	ØD1	B	H	L	
TT PRO 150	5 7/8"	7 3/4"	8 1/2"	9 7/8"	11 3/8"	6.0

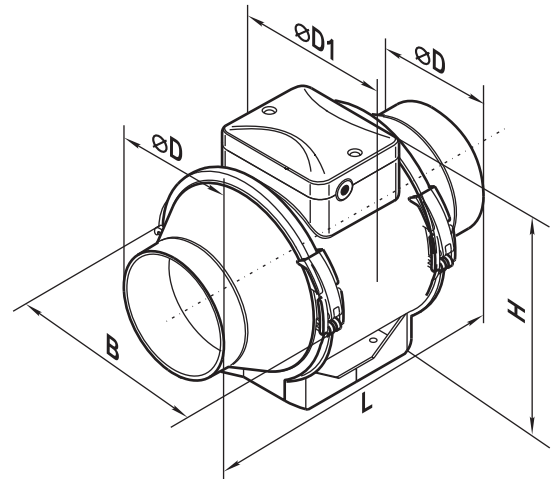

PERFORMANCE

Model	Duct dia	Speed	RPM*	Watts*	Amps*	CFM vs. Static Pressure (Ps) in WG										Max Ps. in WG	Volts	
						0	0.1	0.2	0.3	0.4	0.5	0.6	0.7	0.8	0.9			1
TT PRO 150	6"	high	2981	81	0.69	372	361	350**	337	322**	307	293**	275	261	226	108	1.37	120 V / 60 Hz
		low	2432	76	0.64	304	288	270**	251	233**	213	192**	158	109	72	48	1.22	

* The parameters RPM, Watts, Amps are indicated at 0.2 in WG static pressure.