



### DESCRIPTION

TwinFresh Expert RW1-100-2 V.2 designed to ensure filtration and supply of fresh air into the room as well as exhaust of stale air with energy regeneration. No freezing and condensation during operation. Efficient supply and exhaust single-room ventilation air flow up to 64 CFM.

### KEY FEATURES:

- Unique Single Room Energy Recovery Ventilator.
- One TwinFresh Expert unit in ventilation mode can serve rooms up to 500 sq. ft.\*
- Controlled by Android or iOS smartphone through the cloud server from any part of the world.
- Wi-Fi communication between several ventilators for coordinated operation.
- High-tech ceramic energy regenerator with max. heat recovery efficiency up to 70 %.
- Built-in Humidity sensor, Timer and Weekly Scheduler.
- Automatic air shutters.
- MERV 5 filters (optionally MERV 13 filter).
- Antibacterial treatment of ERV core and filters.
- Easy installation and maintenance.

\*In accordance with ANSI/ASHRAE Standard 62.2-2016

### DIMENSIONS

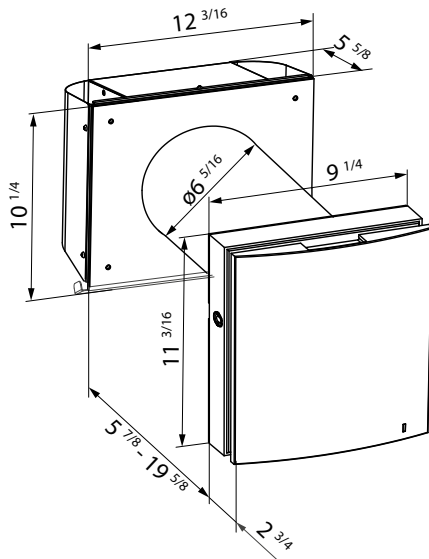

### MOTOR

DC motor with outstanding low energy demand from 3.20 W. The fan is powered by safe voltage 12 V. The motor has integrated overheating protection and ball bearings for long service life.

### PERFORMANCE

Model	TwinFresh Expert RW1-100-2 V.2			
Speed	1	2	3	max
Supply voltage, 50/60 Hz [V]	1~100~240			
Power [W]	3.20	4.00	6.60	18.00
Max. current consumption [A]	0.037	0.046	0.059	0.151
Air flow in ventilation mode [CFM]	11	18	30	64
Air flow in regeneration mode [CFM]	5	9	17	32
RPM	780	1100	1920	2940
Sound pressure level @ 3 ft [Sones]	0.2	0.4	2.2	5.0
Noise attenuation according to DIN EN ISO 10140-2: 2010 [Sones]	2,5			
Indoor/outdoor airtightness classification of the complete unit in accordance with EN 13141-8	D1			
Transported air temperature [°F]	-4...104 (-20...+40)			
Regenerating efficiency [%]	≤ 87			
Ingress Protection	IP24			

MODEL	QUANTITY	COMMENTS	PROJECT
			location:
			architect:
			engineer:
			contractor:
			submitted by:

Tel: 888-640-0925  
513-583-5786

Sales@vents-us.com  
Vents-US.com  
400 Murray Rd,  
Cincinnati, OH 45217

