

USER'S MANUAL

TwinFresh Expert RW1 -50

TwinFresh Expert Duo RW1 -30



Single-room reversible energy recovery ventilator

CONTENTS

Safety requirements.....	2
Purpose.....	7
Delivery set.....	8
Designation key.....	8
Technical data.....	9
Design and operating principle.....	10
Mounting and set-up.....	12
Connection to power mains and control.....	15
Technical maintenance.....	27
Troubleshooting.....	29
Storage and transportation regulations.....	29
Manufacturer's warranty.....	30
Certificate of acceptance.....	31
Seller information.....	31
Installation certificate.....	31
Warranty card.....	31

This user's manual is a main operating document intended for technical, maintenance, and operating staff.

The manual contains information about purpose, technical details, operating principle, design, and installation of the TwinFresh Expert (Duo) RW1 unit and all its modifications.

Technical and maintenance staff must have theoretical and practical training in the field of ventilation systems and should be able to work in accordance with workplace safety rules as well as construction norms and standards applicable in the territory of the country.

SAFETY REQUIREMENTS

- read and save these instructions
- the unit must be grounded!
- do not bend the power cable.
- avoid damaging the power cable.
- do not put any foreign objects on the power cable.
- do not use damaged equipment or cables when connecting the unit to power mains.
- do not touch the unit controls with wet hands.

- do not carry out the installation and maintenance operations with wet hands.
- do not allow children to operate the unit.
- do not store any explosive or highly flammable substances in close proximity to the unit.
- do not open the unit during operation.
- do not block the air duct when the unit is switched on.
- do not sit on the unit and avoid placing foreign objects on it.
- unpack the unit with care.
- while installing the unit, follow the safety regulations specific to the use of electric tools.
- do not lay the power cable of the unit in close proximity to heating equipment.
- do not operate the unit outside the temperature range stated in the user's manual.
- do not operate the unit in aggressive or explosive environments.
- do not wash the unit with water.
- protect the electric parts of the unit against ingress of water.
- disconnect the unit from power mains prior to any technical maintenance.
- when the unit generates unusual sounds, odor, or emits smoke, disconnect it from power supply and contact the seller.
- do not direct the air flow produced by the unit towards open flame or ignition sources.
- in case of continuous operation of the unit, periodically check the security of mounting.

- please read the user's manual carefully prior to installing, connection to power mains and operating the unit.
- the manufacturing company shall not be responsible for damage to health and property of the customer caused by the customer's violating the user's manual.
- follow the user's manual requirements to ensure durable operation of the unit, its mechanical and electrical reliability.
- the unit should not be operated by children or persons with reduced physical, mental, or sensory capacities, or those without the appropriate training.
- the choice of unit installation location must prevent unauthorized access by unattended children.
- read the user's manual before installing the unit.
- installation work and electrical wiring must be done by qualified person(s).
- when cutting or drilling into wall or ceiling, do not damage electrical wiring and other hidden utilities.
- do not mount room-to-room fan in a fire-rated wall.
- power off the power supply prior to any operations with the unit.
- the unit must be connected to power supply by a qualified electrician.
- the rated electrical parameters of the unit are given on the manufacturer's label.
- any tampering with the internal connections is prohibited and will void the warranty.
- installation only by experts and only in accordance with

- local requirements and national electrical code
- disconnect the unit from power supply before any maintenance operations!
- ensure that the unit is switched off from the supply mains before removing the guard.
- following the regulations stipulated herein will ensure a long and trouble-free operation of the unit
- user's warranty claims shall be subject to review only upon presentation of the unit, the payment document and the user's manual with the purchase date stamp
- warning - to reduce the risk of fire, electric shock, or injury to persons, observe the following:
 - -use this unit only in the manner intended by the manufacturer. if you have questions.contact the manufacturer.
 - -before servicing or cleaning unit, switch power off at service panel and lock the service disconnectin means to pevent power from being switched on accidentally. when the service disconnecting means cannot be locked, securely fasten a prominent warning device, such as a tag, to the service panel
- for general ventilating use only. do not use to exhaust
- hazardous or explosive materials and vapors.
- not for outdoor use
- for residential installation only

- the unit is intended only for free-air discharge or for connection to a duct supplying only one room
- do not install in a cooking area or connect directly to any appliance.
- no condensing water - electronic part is supplied all the time, indoor and shielded from air flow.
- no air with humidity will pass through compartments with hazardous electrical components and connections.
- do not block the air duct of the installed ventilator with dust accumulating materials, such as curtains, cloth shutters, etc.
- as it prevents air circulation in the room.
- power off the power supply prior to any operations with the unit.
- the unit must be connected to power supply by a qualified electrician.
- the rated electrical parameters of the unit are given on the manufacturer's label.
- should be connected through switch, built into the fixed wiring according local installation rules

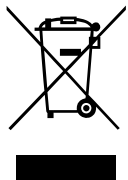

THE PRODUCT MUST BE DISPOSED SEPARATELY AT THE END OF ITS SERVICE LIFE.

DO NOT DISPOSE THE UNIT AS UNSORTED DOMESTIC WASTE

PURPOSE

The unit is designed to ensure continuous mechanical air exchange in houses, offices, hotels, cafes, conference halls, and other utility and public spaces as well as to recover the heat energy contained in the air extracted from the premises to warm up the filtered stream of intake air. The unit is not intended for organizing ventilation in swimming pools, saunas, greenhouses, summer gardens, and other spaces with high humidity. Due to the ability to save heating energy by means of energy recovery, the unit is an important element of energy-efficient premises. The unit is a component part and is not designed for stand-alone operation. It is rated for continuous operation.

Transported air must not contain any flammable or explosive mixtures, evaporation of chemicals, sticky substances, fibrous materials, coarse dust, soot and oil particles or environments favourable for the formation of hazardous substances (toxic substances, dust, pathogenic germs).

DELIVERY SET

Name	TwinFresh Expert RW1	TwinFresh Expert Duo RW1
Indoor unit of the ventilator	1 pc.	1 pc.
Air duct	1 pc.	1 pc.
Air flow separator	–	3-6 pcs.
Sound-absorbing material	1 pc.	–
Assembled cartridge	1 pc.	1 pc.
Outer ventilation hood	1 pc.	1 pc.
Remote control	1 pc.	1 pc.
Cardboard template	1 pc.	1 pc.
USB-A - USB mini cable	1 pc.	1 pc.
Mounting kit	2 packs	2 packs
Foam wedges	1 set	1 set
User's manual	1 pc.	1 pc.
Mounting hood installation instruction	1 pc.	1 pc.
Packing box	1 pc.	1 pc.

DESIGNATION KEY

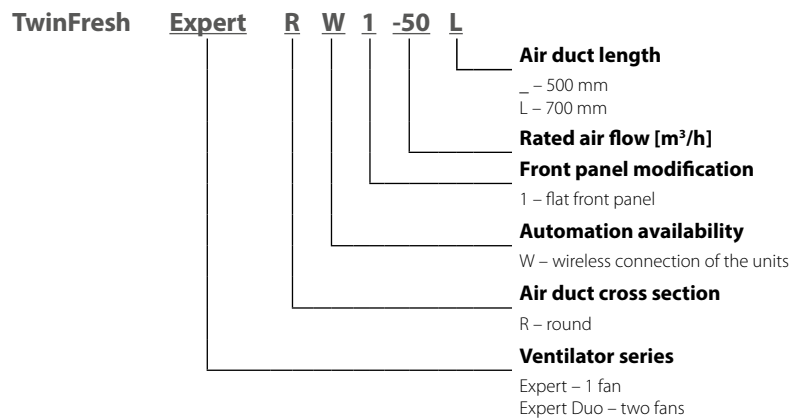

TECHNICAL DATA

The unit is rated for indoor application with the following conditions:

- Temperature ranging from -15 °C (5 °F) up to +40 °C (+104 °F) and relative humidity up to 50 % for TwinFresh Expert RW1 units.
- Temperature ranging from -15 °C (5 °F) up to +40 °C (+104 °F) and relative humidity up to 65 % for TwinFresh Expert Duo RW1 units.

The unit is rated as a class II electric appliance.

Ingress protection rating against access to hazardous parts and water ingress is IP22.

The unit design is constantly being improved, thus some models may be slightly different from those described in this manual.

Technical specifications of the particular model are indicated on the unit casing.

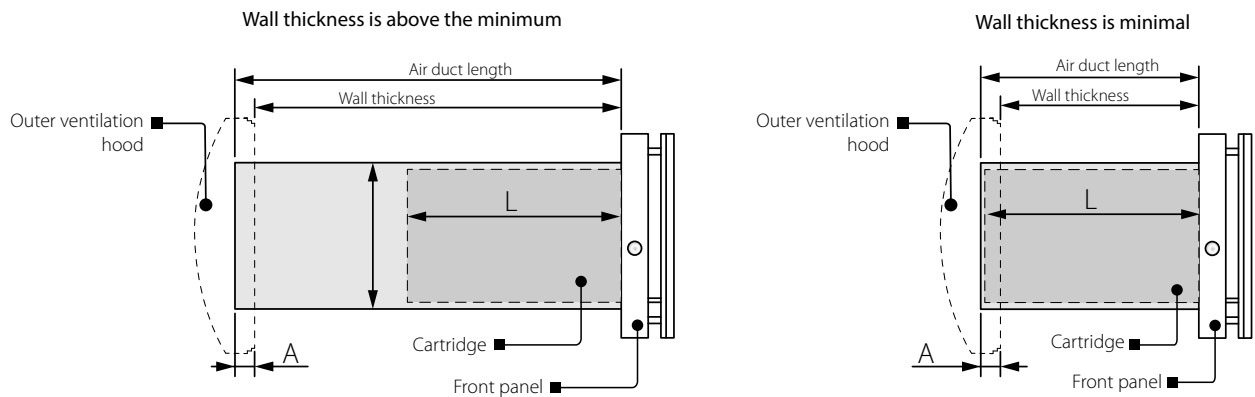

A – protruding part of the air duct on the outer wall. Depends on the selected ventilation hood type.

L – cartridge length, depends on the ventilator model.

Ventilator model	L, [mm]
TwinFresh Expert RW1-50	250
TwinFresh Expert Duo RW1 -30	280

The supplied air duct length and the supplied ventilation hood model depends on the ventilator model, refer to the Designation Key section, page 7. The overall and connecting dimensions of the outer ventilation hood, the outside protrusion length of the air duct A and the mounting sequence of the hood are stated in its installation instruction.

The overall dimensions of the front panel are stated below.

OVERALL DIMENSIONS OF THE INDOOR UNIT [mm] (inch)

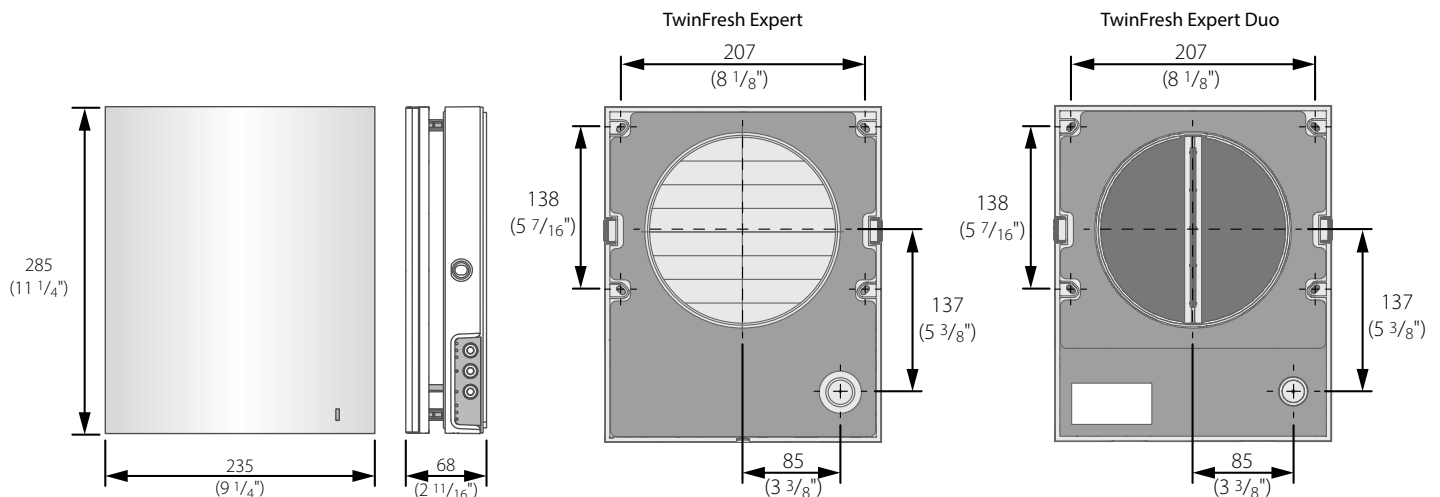

Wi-Fi technical data

Standard	IEEE 802,11, b/g/n
Frequency band [GHz]	2.4
Transmission power [mW] (dBm)	100(+20)
Network	DHCP
WLAN safety	WPA, WPA2

DESIGN AND OPERATING PRINCIPLE

The ventilator consists of an indoor unit with a decorative front panel, a cartridge, an air duct with a sound absorbing layer and an outer ventilation hood.

The cartridge is a basic functioning part of the ventilator.

The cartridge consists of the fan, the regenerator and two filters that ensure rough air filtration and prevent ingress of dust and foreign objects into the heat exchanger and the fan.

The indoor assembly unit is equipped with automatic shutters that close during the ventilator standstill and prevent air backdraft.

The **TwinFresh Expert Duo RW1** units are equipped with a set of air flow separators. The design of the supplied ventilation hood ensures opposite direction of extract and supply air flows.

The outer ventilation hood is used to prevent direct ingress of water and other objects to the ventilator.

VENTILATOR DESIGN

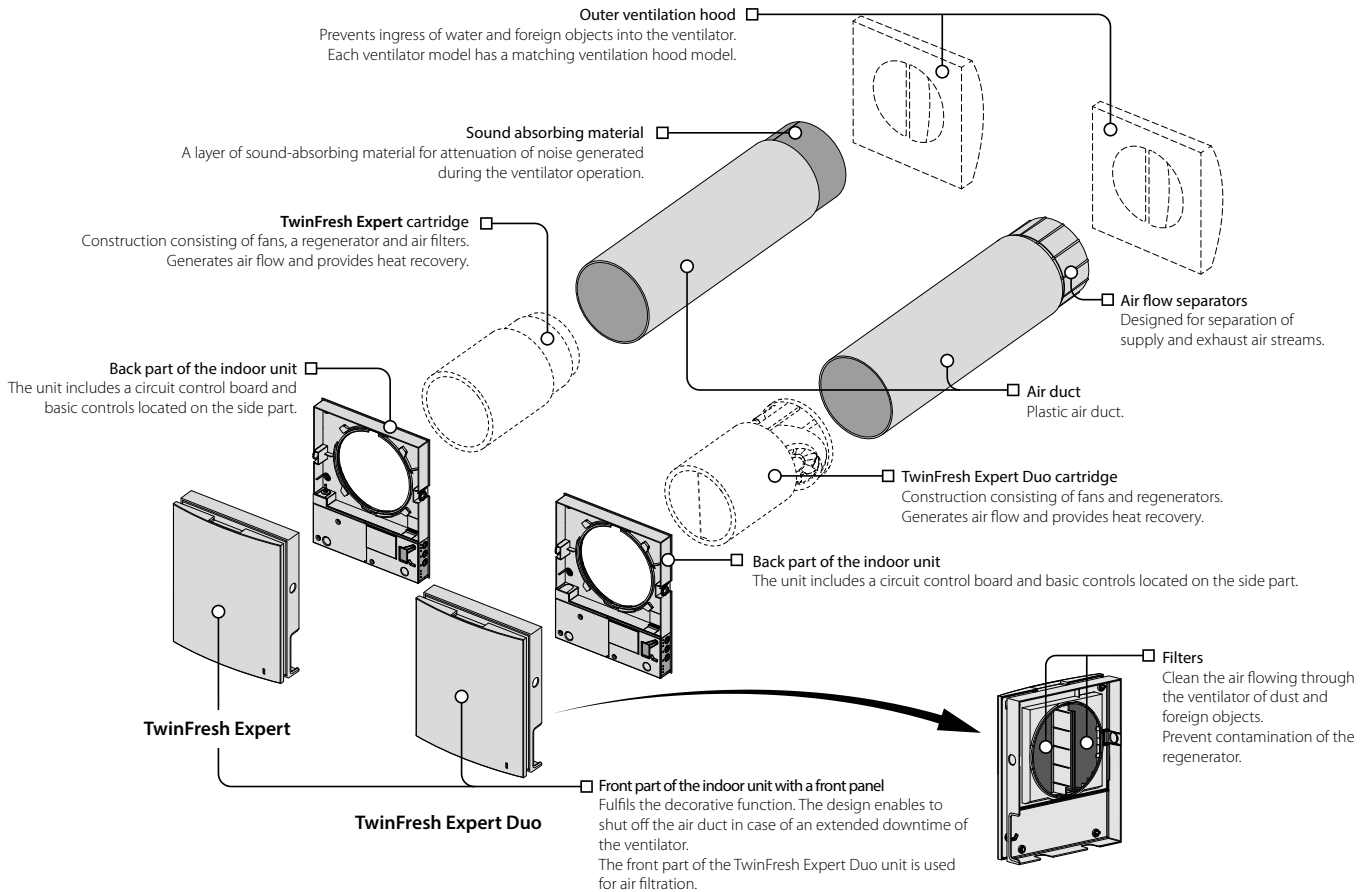

OPERATING LOGIC OF THE AUTOMATIC SHUTTERS

The indoor unit is equipped with automatic shutters.

During the ventilator operation the automatic shutters are opened and let the air flow freely through the ventilator.

The automatic shutters are closed for 2 minutes at the ventilator shut down.

The shutters are closed

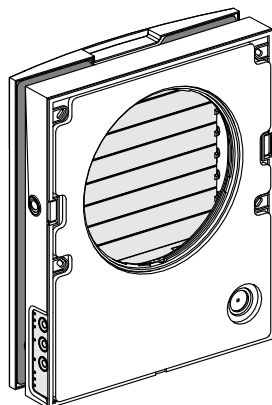

The shutters are open

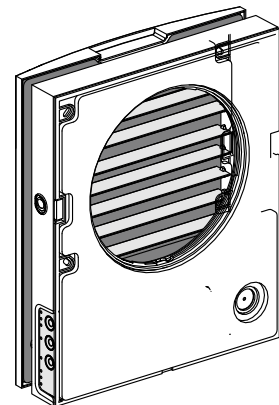

VENTILATOR OPERATION MODES

TwinFresh Expert RW1	TwinFresh Expert Duo RW1
<p>Ventilation: the ventilator runs either in air extraction or air supply mode at a set speed. In this mode some of the ventilators in the network run in air supply mode and the other ones in air extraction mode, depending on the direction set using the personal computer (see page 18). Regeneration: the ventilator runs in two cycles, 70 seconds each, with heat and humidity regeneration.</p> <p>Cycle I. Warm stale air is extracted from the room and flows through the ceramic regenerator, which gradually absorbs heat and humidity. In 70 seconds, as the ceramic regenerator gets warmed, the ventilator is switched to air supply mode.</p> <p>Cycle II. Fresh intake air from outside flows through the ceramic regenerator, absorbs accumulated moisture and is heated up to the room temperature. In 70 seconds, as the ceramic regenerator gets cooled down, the ventilator is switched to air extraction mode and the cycle is renewed. If two ventilators are installed, they operate with opposite rotation directions in this mode. While one ventilator supplies air, the other one extracts it.</p> <p>Boost mode is activated when the external relay sensor, the external 0-10 V analogue sensor or the integrated humidity sensor is triggered. The ventilator operates at maximum speed without changing the operation mode. After all sensors return to normal state or upon elapse of the turn-off delay timer countdown (from 0 up to 24 hours, factory setting 30 minutes) the ventilation unit reverts to the previous speed.</p> <p>Supply mode is activated only using the mobile application. The ventilator operates in the supply mode irrespective of the air flow direction set via the personal computer (see page 18).</p>	<p>One fan operates in the air extraction mode and the other fan operates in the air supply mode at set speed. The fans do not change their rotation direction.</p> <p>Regeneration - one of the ventilator fans operates in the air extraction mode and the other one operates in the air supply mode. The fans change their rotation direction every 70 seconds.</p> <p>Boost mode is activated when the external relay sensor, the external 0-10 V analogue sensor or the integrated humidity sensor is triggered. The ventilator operates at maximum speed and follows one of two functioning algorithms to be set during setup of the ventilation unit via a PC. For details, refer to page 18.</p> <p>Humidity control scenario:</p> <ul style="list-style-type: none"> • Increase speed and switch to air extraction mode (both fans operate at air extraction mode) • Increase speed in current mode. <p>After all sensors return to normal state or upon elapse of the turn-off delay timer countdown (from 0 up to 24 hours, factory setting 30 minutes) the ventilation unit reverts to the previous speed.</p> <p>Supply mode is activated only using the mobile application. Both fans operate in air supply mode.</p>

MOUNTING AND SET-UP

1. Prepare a round core hole in the outer wall.

The hole size is shown in the figure below.

While preparing core holes it is recommended to make preparations for layout of the power cable and other required cables.

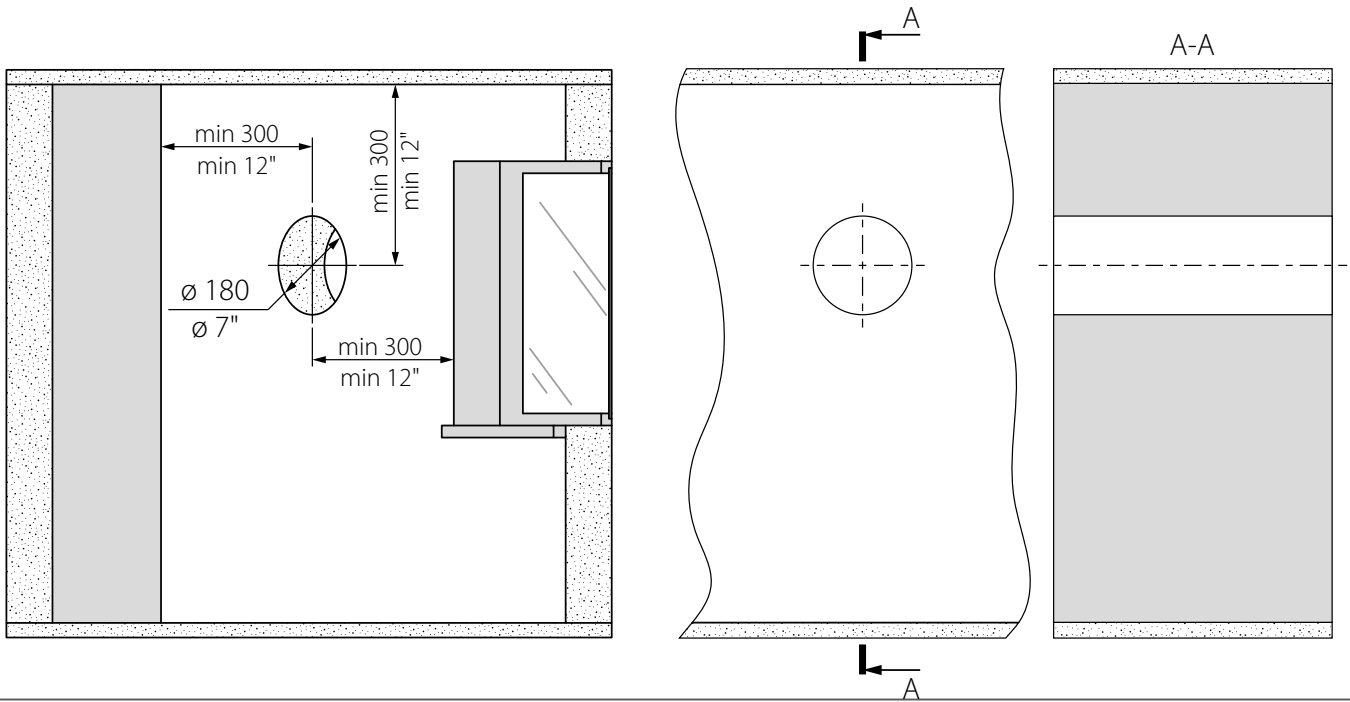

2. Install the air duct in the wall and fix it with mounting foam.

The air duct end must protrude for the distance that enables installation of the outer ventilation hood (see the User's manual for the outer ventilation hood).

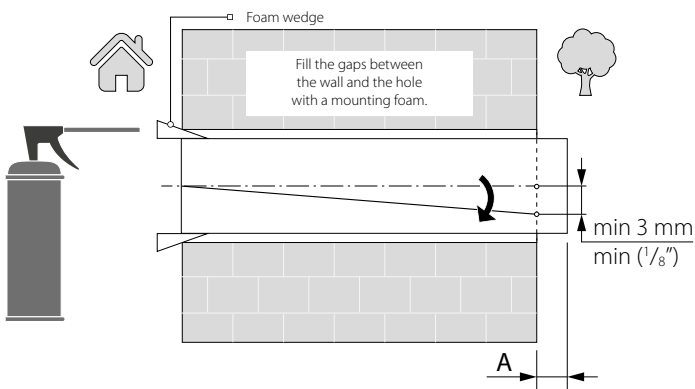

Install the air duct in the wall in such a way so it protrudes from the wall surface for maximum 3 mm or is flush with the wall. Install the air duct with the minimum slope 3 mm downwards. On the outer wall side the air duct end must protrude to a distance that enables installation of the outer ventilation hood. Distance A is stated in the installation instruction for the ventilation hood.

3. Stick the delivered cardboard master plate on the indoor wall using a mounting tape. The large opening in the master plate must be axially aligned with the air duct. For aligning the master plate with respect to the horizon line it is recommended to use a builder's level. Then mark the fastening holes for installation of the supplied dowels and drill the holes to a required depth. Route the power cable from the wall outside through the specially marked opening on the master plate.

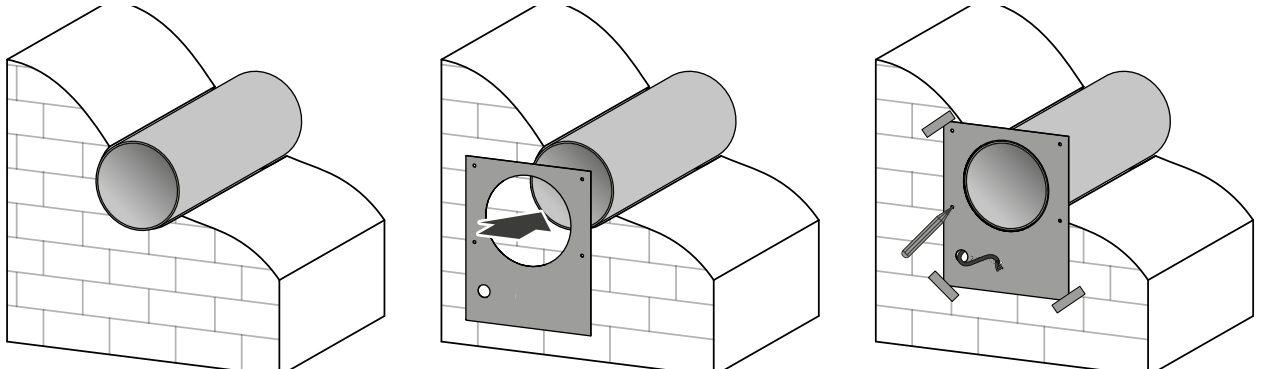

4. Unlatch and detach the front part of the indoor unit from its back part.

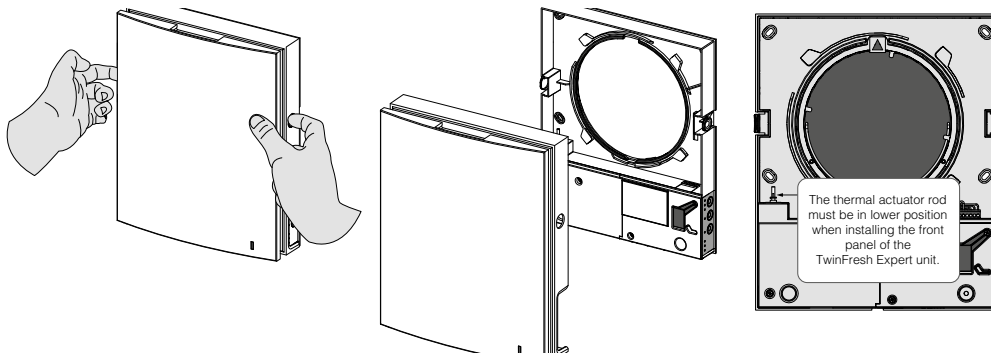

5. Fix the back part of the indoor unit on the wall with the screws supplied with the mounting kit of the ventilator. Remove the two retaining screws from the left transparent cover to enable access to the terminals.

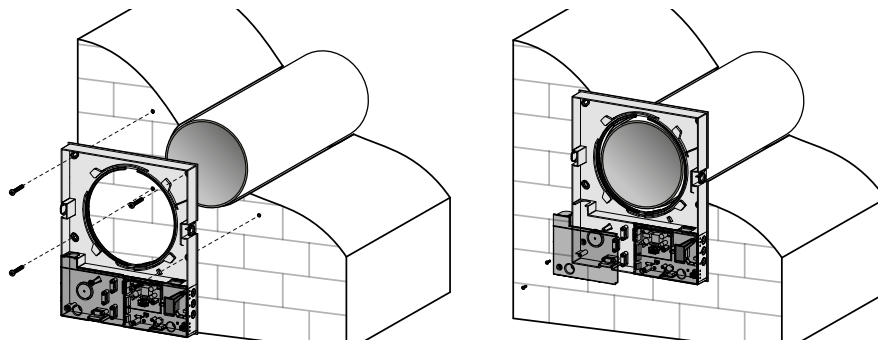

6. Route the power cable as figured below and connect the ventilator to power mains in compliance with the external wiring diagram, refer to Page 12.

Fix the power cable and the signal cables with cable clamps.

After completion of the electrical connection re-install the transparent cover in site.

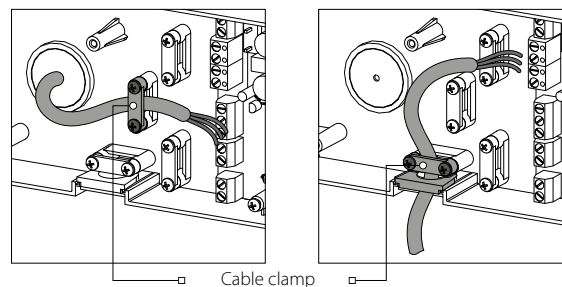

7. Install the cartridge into the air duct as figured below. The pointer must be directed upwards. Then fix the wire with the protruding clamp and connect the connector to the circuit board.

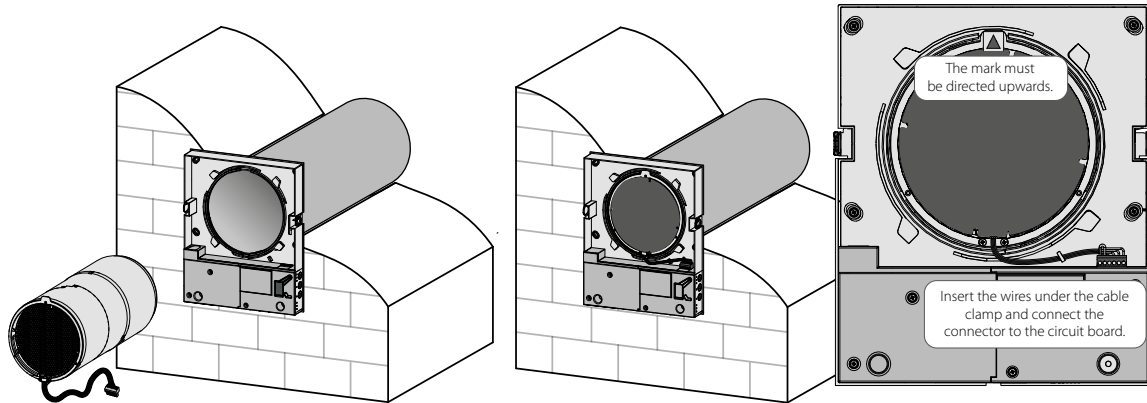

8. Install the front part of the indoor unit. The air shutter actuator rod must be in lower position, as shown in the figure in Section 4 on page 10.

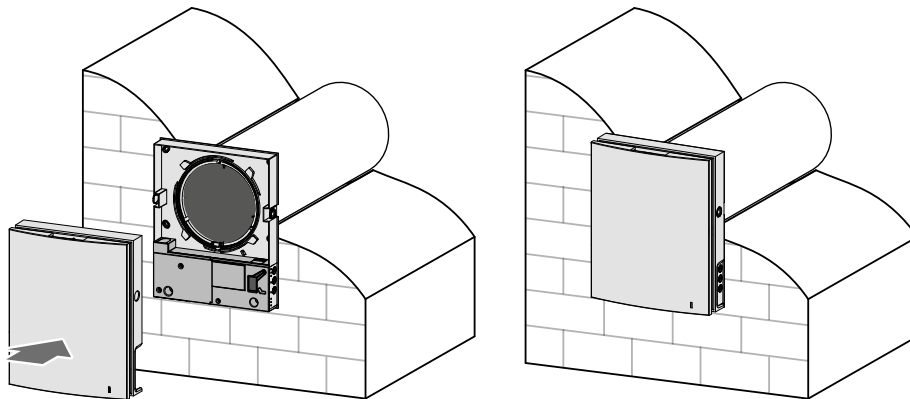

TwinFresh Expert Duo RW1-30

9. Insert the sound absorbing layer into the air duct from the outside. Roll the layer of the sound absorbing material to match the air duct diameter. The protecting paper layer must be outside. Insert the sound absorbing roll into the cartridge against stop. Make a mark at the end of the air duct, remove the material and cut the roll as marked. Insert the ready sound absorbing roll into the air duct.

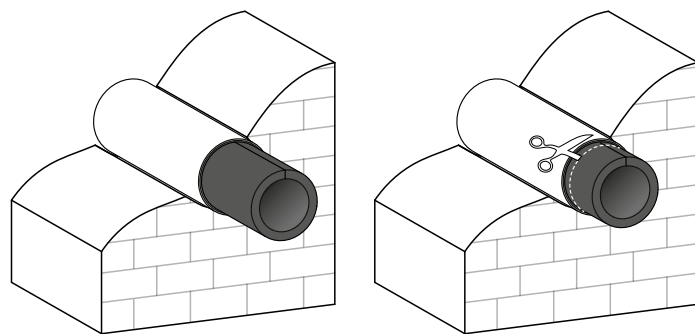

TwinFresh Expert Duo RW1-30

9. Install the sectional air flow separators from the outside. Install a required quantity of the air flow separators in the air duct until it bumps up the cartridge. Mark the last air flow separator to be flush with the air duct face, remove it from the air duct and cut the excessive part of the last air flow separator. Tighter fixation is provided if the air flow separator protrudes to some distance. Install the adjusted air flow separators in the air duct.

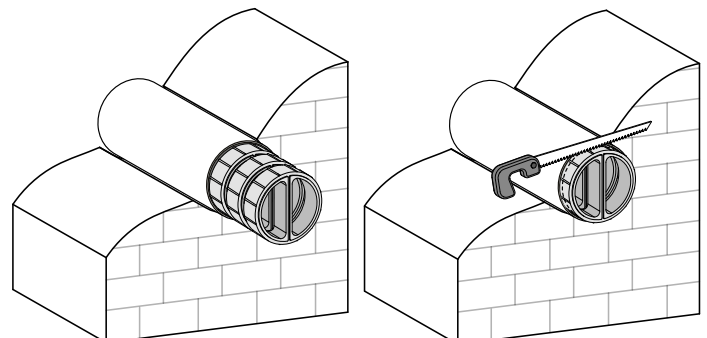

10. Install the outer ventilation hood. For this, see the user's manual for the hood.

CONNECTION TO POWER MAINS AND CONTROL

WARNING! SHOULD BE CONNECTED THROUGH SWITCH, BUILT INTO THE FIXED WIRING ACCORDING LOCAL INSTALLATION RULES

The ventilator is rated for connection to single-phase AC 120V 60Hz power mains.

Connect the unit to power mains through the external automatic switch with a magnetic trip integrated into the fixed wiring system.

Use a two-pole circuit breaker with type B protection.

Note that the rated current of the circuit breaker for one ventilator is not more than 1 A, and for a network of ventilators with common power supply not more than 3 A (no more than 10 ventilators in one network).

Use flexible wires for electrical connection.

The cross section of the conductors must be selected at intervals from the tables below.

Type of connection	Min. cross section [mm ²] (AWG)	Max. cross section [mm ²] (AWG)
Power cable	0,5 mm ² (20 AWG)	2,5 mm ² (14 AWG)
Signal cable	0,25 mm ² (22 AWG)	1,5 mm ² (16 AWG)

The cable cross-section is given for reference only.

The actual conductor cross-section selection must be based on its type, maximum permissible heating, insulation, length and installation method.

Use copper wires for all the electric connections!

Connect the ventilator to power mains in compliance with the wiring diagram.

The ventilator design enables connecting any external controls with normally opened contacts (NO-contacts), such as an external CO₂ sensor, a humidity sensor, a switch, etc.

When the contacts of the NO contact of the external device are closed, the unit changes to the maximum speed.

An analogue sensor with output voltage 0-10 V is also compatible with the unit.

EXTERNAL CONNECTIONS DIAGRAM

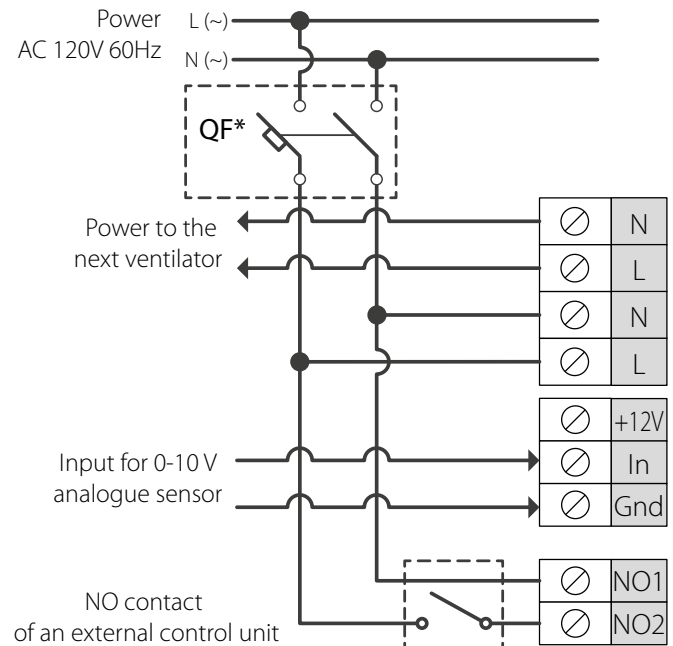

* The units are not included in the delivery set

VENTILATOR SETUP

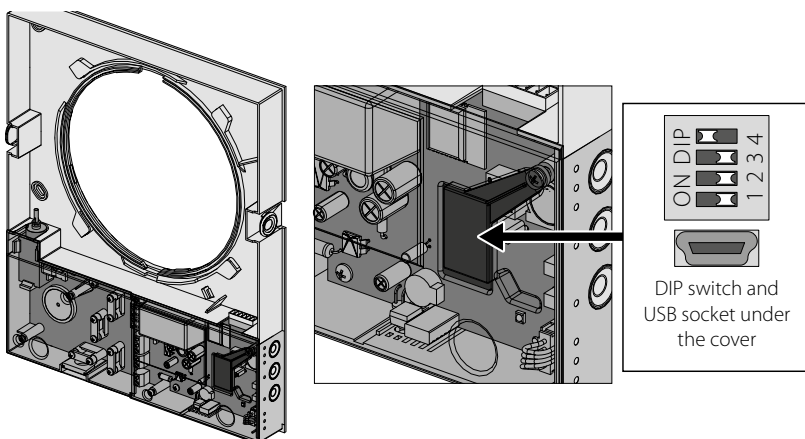

Prior to operating the ventilator set up the ventilator using the DIP switch. It is located on the controller circuit board.

To access the DIP switch, take off the front panel of the indoor unit and uplift the rubber plug that covers the switch.

The USB socket that enables connection of the unit to a PC is located under the rubber cover.

POSITIONING OF THE DIP SWITCHES

Ventilator operation mode	
	2 The main operation mode in which the Wi-Fi parameters (specified in the Vents TwinFresh application on the PC) are applied.
	1 To activate this mode, set the first and second jumpers to OFF position. Turn the power supply to the unit off and on to apply the parameters.
	2 Demo Slave mode: set the first jumper to ON position and set the second jumper to OFF position. Turn the power supply to the unit off and on to apply the parameters.
	1 The mode description see on page 25.
	2 Demo Master mode: set the first and the second jumper to ON position. Turn the power supply to the unit off and on to apply the parameters.
	1 The mode description see on page 25.
Resetting to factory settings:	
	2 To reset the factory settings, set the first jumper to OFF position and the second jumper to ON position. Turn the power supply to the unit off and on to apply the parameters.
	1 After resetting, return the jumpers to the previous position.
Resetting timer filter	
	3 To reset the filter timer, set the third jumper to ON position and then revert it to OFF position.
Service mode	
	4 Download mode for the basic firmware: set the fourth jumper to OFF position. Turn the power supply to the unit off and on to apply the parameters.
	4 Normal operation of the unit: set the fourth jumper to ON position. Turn power supply to the unit off and on to apply the parameters.



VENTILATOR CONTROL

The ventilation unit may be operated with the following controls:

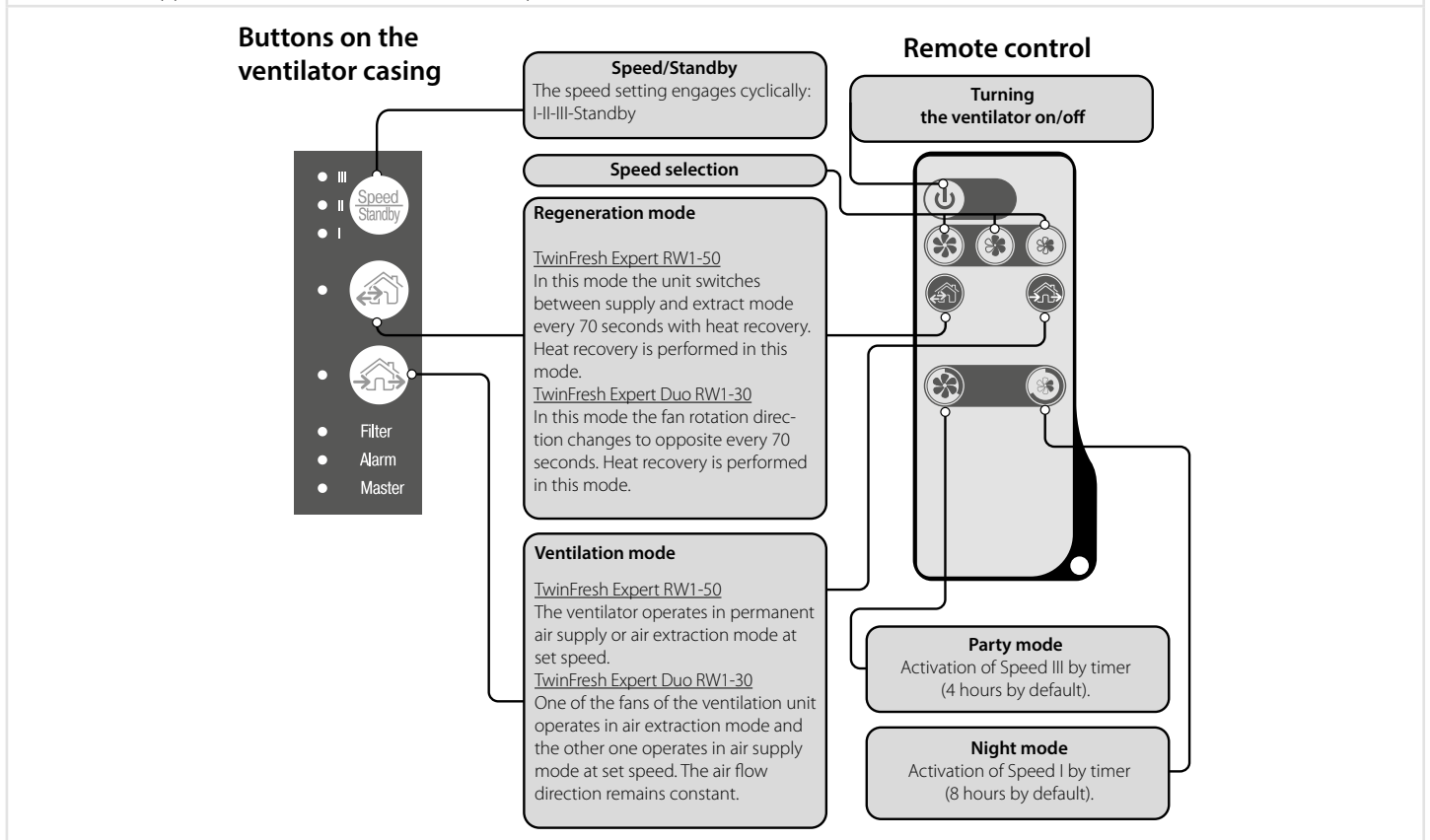





- infra-red remote control
- control - located on the side of the indoor unit (see the figure below)
- Vents Home application from a mobile device (smartphone or tablet)



VENTILATOR CONTROL WITH THE BUTTONS ON THE INDOOR UNIT

	<p>The speed selection sequence is follows: I-II-III-Standby</p> <p>All the units integrated in a single network operate according to the speed settings of the Master unit.</p> <p>I: permanent indicator glowing indicates operation of the unit at Speed I. The indicator blinks when the first speed timer is activated.</p> <p>I and II: permanent glowing of the indicators I and II indicates operation of the unit at Speed II.</p> <p>I, II and III: permanent glowing of the indicators I, II and III indicates operation of the ventilator at Speed III.</p> <p>Blinking of the indicators I, II and III indicates activation of the timer for Party mode or the turn-off delay timer triggered by any connected external sensors or the integrated humidity sensor.</p> <p>Alternate blinking of the indicators I, II and III indicates that the ventilator runs at the speed set with the mobile application using the slider selector for manual speed setting.</p>
	<p>Regeneration mode.</p> <p><u>TwinFresh Expert RW1</u></p> <p>The rotation direction of both fans changes to opposite every 70 seconds. Heat recovery is performed in this mode. When several ventilators are operating on the network, it is necessary to configure a different direction of rotation of the fans using the application on a PC.</p> <p><u>TwinFresh Expert Duo RW1</u></p> <p>The rotation direction of both fans changes to opposite every 70 seconds. Heat recovery is performed in this mode.</p>
	<p>Ventilation mode.</p> <p><u>TwinFresh Expert RW1</u></p> <p>The ventilator operates in permanent air supply or air extraction mode at set speed.</p> <p>The ventilation unit operates in the air supply or extraction mode with a set speed. The fan rotation direction depends on PC setting (air extraction mode by default).</p> <p><u>TwinFresh Expert Duo RW1</u></p> <p>One fan operates in the air extraction mode and the other fan operates in the air supply mode at set speed. The fans do not change their rotation direction.</p>
<p>No glowing of the indicators «Regeneration» and «Ventilation» indicates forced operation of the ventilation unit in the air supply mode. This mode may be activated only via the mobile application.</p>	
Filter	<p>Contamination indicator of filters.</p> <p>90 days (continuous operation) after installation of the cartridge the Filter contamination indicator starts glowing.</p> <p>In this case, clean or replace the filters (see the «Technical maintenance» section).</p> <p>Reset the timer after filter replacement:</p> <ul style="list-style-type: none"> • ventilators operating in Master mode using a DIP switch, an application on a mobile device or using a PC; • ventilators operating in Slave mode using a DIP switch or PC.
Alarm	<p>Alarm indicator for emergency shutdown of the unit. Permanent glowing of the Alarm indicator of the Master unit indicates an alarm in the network of the connected ventilation units. Its blinking indicates shutdown of a specific ventilation unit in the network.</p> <p>In case of an emergency shutdown of a TwinFresh Expert RW1 unit in the network the defective ventilation unit is marked with the blinking Alarm indicator. All the connected TwinFresh Expert RW1 ventilation units are also stopped. All the connected TwinFresh Expert Duo RW1 ventilation units continue operating. In case of an emergency shutdown of a TwinFresh Expert Duo RW1 unit in the network the defective ventilation unit is marked with the blinking Alarm indicator. The defective ventilation unit shuts down and the other connected ventilation units continue their operation.</p>
Master	<p>Master unit indicator</p> <p>Permanent glowing of the indicator shows the leading unit in the network (Master unit).</p> <p>Indicator blinking indicates the driven unit (Slave unit) and no connection to the Master unit.</p> <p>No glowing of the lamp indicator means that this ventilation unit is a Slave ventilation unit and it is connected to a Master unit.</p>
<p>Synchronous blinking of all the lamp indicators on the casing of the ventilation unit means active setup mode performed by a PC. In this case the fan shuts down.</p>	

REMOTE CONTROL OF THE VENTILATION UNIT

	<p>Turning the ventilator on/off. The unit may be turned off only if it is enabled by the settings. Reset of alarm and timer settings.</p>
	<p>Ventilator speed selection: Speed III-II-I respectively.</p>
	<p>Regeneration mode. <u>TwinFresh Expert RW1</u> The rotation direction of both fans changes to opposite every 70 seconds. Heat recovery is performed in this mode. <u>TwinFresh Expert Duo RW1</u> The rotation direction of both fans changes to opposite every 70 seconds. Heat recovery is performed in this mode.</p>
	<p>Ventilation mode. <u>TwinFresh Expert RW1</u> The ventilator operates in permanent air supply or air extraction mode at set speed. The ventilation unit operates in the supply or extract mode with a set speed. The fan rotation direction depends on PC setting (extract mode by default). <u>TwinFresh Expert Duo RW1</u> One of the fans of the ventilation unit operates in air extraction mode and the other one operates in the supply mode at set speed. The air flow direction mains constant.</p>
	<p>Timer control buttons:</p> <ul style="list-style-type: none">  Party mode: the timer activates operation of the unit at Speed III for a set time period, 4 hours by default. The setting may be edited during setup of the unit or using the mobile application.  Night mode: the timer activates operation of the ventilation unit at Speed I for a set time period, 8 hours by default. The setting may be edited during setup of the unit or using the mobile application. The ventilation unit reverts to operation with a previous speed setting upon elapse of the set time period. Press any speed setting key to deactivate the timer or press the timer control button once again.

VENTILATION UNIT OPERATION WITH THE MOBILE APPLICATION

To control the ventilator, download and install the application on your smartphone or tablet.
Use the QR codes below to get download links:

[Vents Home – App Store](#)

[Vents Home – Play Market](#)



WARNING! Before using the mobile app, it is necessary to configure the ventilator on the computer with the software.

CONNECTION OF THE VENTILATION UNIT TO PC

Download and install the software to setup the ventilation unit.

The link for downloading is available at: <https://ventilation-system.com/download>.

Select the document type "Software".

Use the search bar to find the software for the VENTS TwinFresh Expert Wi-Fi devices.

Download the software file.

- Start the VENTS TwinFresh.exe at your PC.
- Take off the front part of the indoor unit for accessing the DIP switch and USB connector on the control board under the rubber cover (refer to Ventilation Unit Setup).
- Connect the ventilation unit and PC using a USB to mini USB cable.
- Select the menu language prior to starting operation (3).
- Select a required unit from the dropdown list Select device. Select the unit (1).
- When a new unit is connected to a PC, the program automatically detects the connected ventilation unit and it is displayed in the dropdown list Select device.

Select an operation mode for the ventilation unit in the network (2). Available parameters for the Master mode: 4-13. Available parameters for the Slave mode: 4-5.

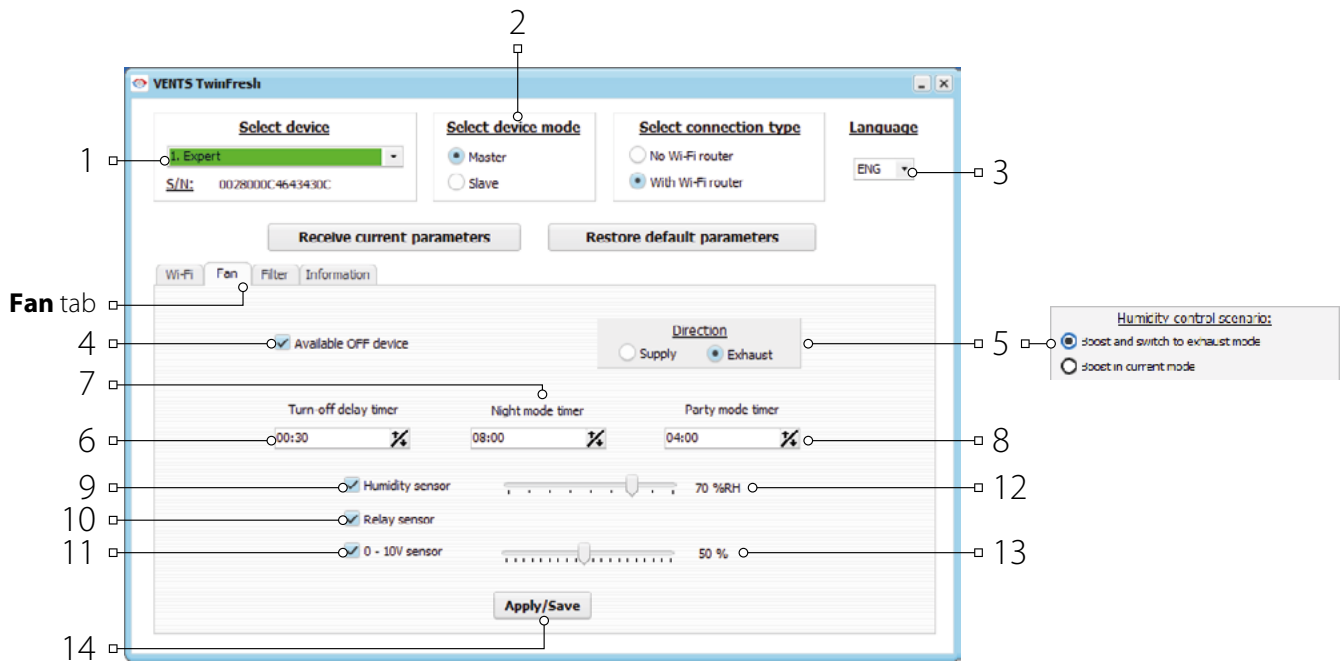

Unit setup:

Prior to starting setup of the unit open the **Fan** tab.

- **Receive current parameters:** reading the settings from the connected unit and saving them in the program.
- **Restore default parameters:** resetting the factory settings in the connected unit.
- **Available OFF device (active by default):** enabling/disabling of the unit turning off.
- The attempt to turn the unit off will turn it to **low speed mode**.
- To disable the function, uncheck «**Available OFF device**».
- **Direction (applicable only for TwinFresh Expert RW1-50):** setting rotation direction of the fan in Ventilation mode. This parameter also sets the fan rotation direction in the **Regeneration** mode.
- **Humidity control scenario (for TwinFresh Expert Duo RW1-30):** setting reaction of the ventilation unit for activation of a sensor.
- **Turn-off delay timer:** setting reset time to a previous operation mode for the ventilation unit after activation of any connected sensors or the built-in humidity sensor.
- **Night mode timer:** setting reset time to the low speed mode after activation of the night mode, factory setting 8 hours.
- **Party mode timer:** setting changeover time for high-speed mode after activation of the Party mode, factory setting 4 hours.
- **Humidity sensor:** activation of the humidity sensor. When the indoor humidity exceeds the set point (12), the unit changes to the high speed. When the indoor humidity drops down below the set point, the turn-off timers starts countdown and then the unit changes to the previous speed.
- **Relay sensor:** activation of the external relay sensor (10). When the no-contact of the external relay sensor is closed, the unit changes to the maximum speed. When the NO-contact is open, the turn-off delay timer starts countdown and then the unit changes to the previous speed.
- **0-10 V sensor:** activation of the external analogue sensor 0-10 V. When a 0-10 V control signal value exceed the set point (13), the ventilation unit changes to the high speed. As the control signal value falls down below the set point, the turn-off timer starts its countdown and upon its elapsing the ventilation unit reverts to operation with the previous speed.
- **Apply:** press the button (14) to apply the parameters in the selected tab.

***Note: settings are not available in the mobile app.**

RESET FILTER TIMER

- Start the program VENTS TwinFresh.exe at your PC.
- Connect the ventilation unit and PC using a USB to mini USB cable.
- Select a required unit from the dropdown list Select device. **Select the unit (1).**
- Select the **Filter** tab.

Press the button **Reset filter timer** (3) to reset the timer. After replacement of the filters the operating hours are displayed above the button (2).

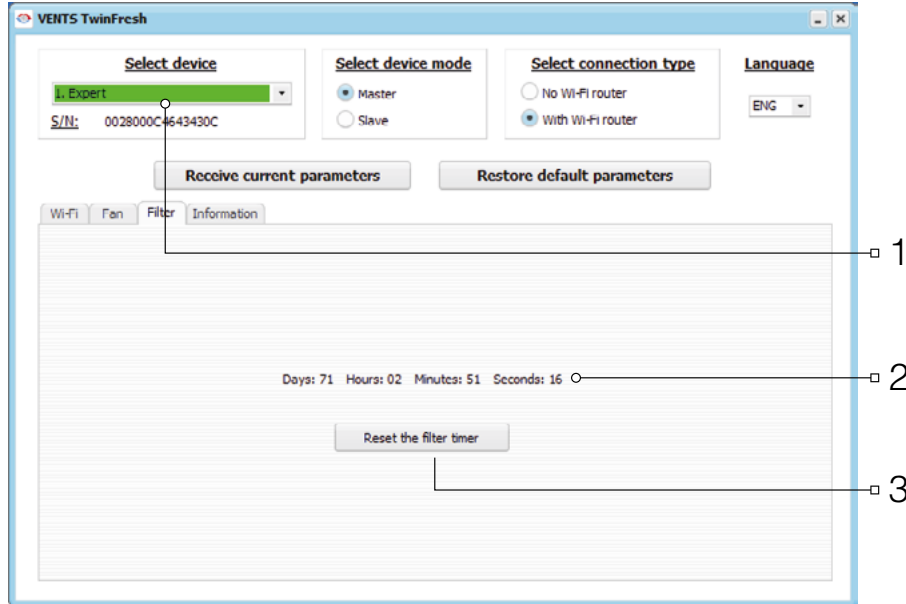

EMERGENCY SHUTDOWN OF THE UNIT

Emergency shutdown of the unit appears if the fan shutdown lasts above 5 seconds.

In case of emergency shutdown of any TwinFresh Expert RW1 unit in a chain all the TwinFresh Expert RW1-50 units stop. The TwinFresh Expert Duo RW1-30 units continue to operate.

In case of emergency shutdown of any TwinFresh Expert Duo RW1-30 unit, all the other units in the chain continue to operate.

The alarm is confirmed by a respective alarm indication for all the ventilation units in the network, see page 16.

To reset the alarm indication troubleshoot the fan shutdown and restart the unit using the button on the indoor unit or the remote control. If the alarm indication is still active, please refer to the Seller.

Cut off power supply to a defective unit to enable operation of the other units in the network.

WIRELESS CONNECTION OF SEVERAL VENTILATION UNITS

The unit operates in two modes:

Master

The unit acts as a leading unit in the network. All the Slave units and mobile devices are connected to the Master unit via Wi-Fi.

The Master unit is operated by means of a mobile device, the remote control or the touch buttons on the unit casing.

The control signal is automatically transferred to the connected Slave units. In this mode the unit responds to a signal from sensors (humidity sensor, external digital sensor, external analogue sensor 0-10 V) and changes its operation mode respectively.

Slave

In this mode the ventilator is controlled by a master unit. The ventilator accepts control signals from the master unit only.

Any other signals from other controls are ignored. In this mode TwinFresh Expert RW1-50 units ignore any other signals from the sensors.

In case of communication loss with the Master unit above 10 seconds the unit is turned off.

Sensors operation

TwinFresh Expert RW1-50 ventilators respond to sensor feedback only in the Master mode.

TwinFresh Expert Duo RW1-30 ventilators respond to sensor feedback in both the Master and the Slave modes.

Upon activation of any of the sensors of TwinFresh Expert RW1-50 units all the ventilators on the network switch to maximum speed whereas TwinFresh Expert Duo RW1-30 units continue operating at the same speed.

Upon activation of any of the sensors of the TwinFresh Expert Duo RW1-30 unit only the affected unit switches to maximum speed according to the humidity control script whereas all the remaining ventilators on the network continue operating at the same speed.

There are two wireless connection options:

1. Connection of up to 4 Slave units or mobile devices to the Master unit with its own wireless access point.

In case of connection of four Slave units to the Master unit with its own wireless access point a mobile device may not be connected.

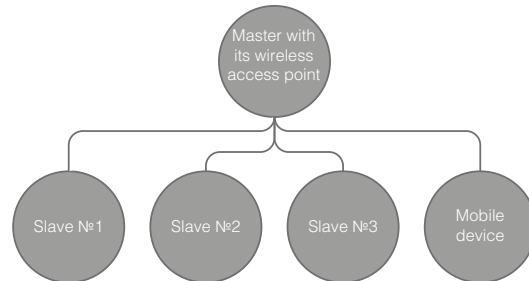

2. The Master units, the Slave units and the mobile devices are connected to a wireless access point of the Wi-Fi router.

In this case the Master unit is able to operate 32 Slave units.

Please note that the Wi-Fi routers may have individual limitations for the maximum number of connected devices.

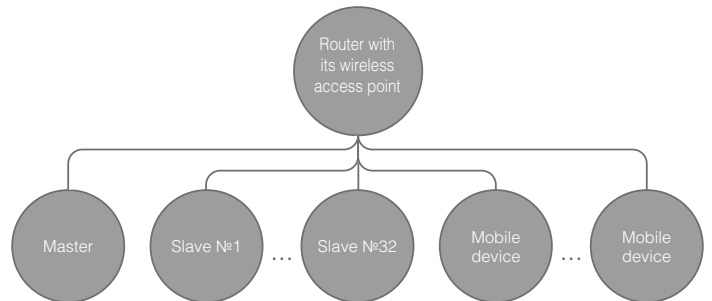

If the Wi-Fi router capacity is not enough to connect a required number of the units, you may use an extra wireless access point to connect the other the unit.

Several Master units can optionally be connected to the network for arranging a zone control.

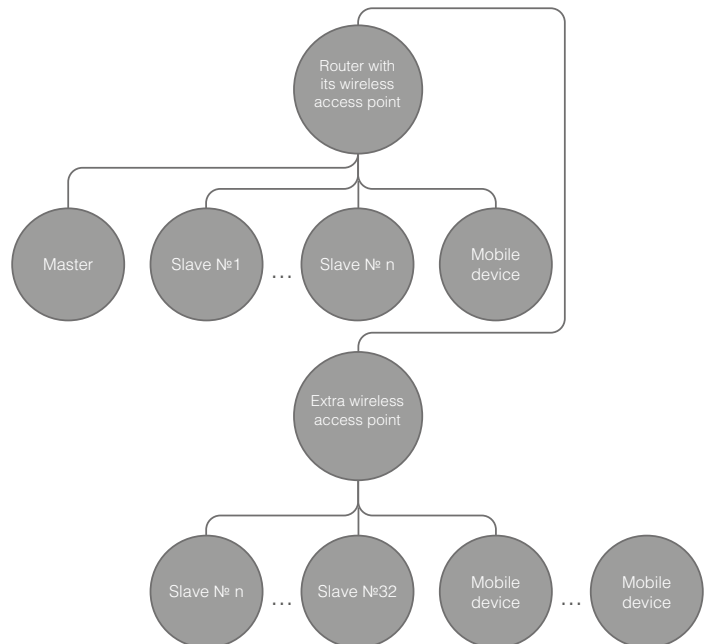

CONFIGURING THE UNIT IN MASTER MODE ACCORDING TO THE DIAGRAM NO. 1

- Start the software at your PC to set up the unit.
- Connect the unit and PC using a USB to mini USB cable.
- Select a required device from the dropdown list (1).
- Select Master for required device mode (2).
- Select **No Wi-Fi router** for the connection type (3).
- Open the tab Wi-Fi (4)
- Select the type of security for the Master point (5). It is an optional requirement.
 - Open: no password.
 - WPA_PSK means a password protected encryption.
 - WPA2_PSK means a password protection encryption.
 - WPA_WPA2_PSK means a password protection encryption.
- Enter a password for the Master wireless access point (6). Wi-Fi password by default: 11111111.
- Select a channel for the Master wireless access point (7). It is an optional requirement.
- Apply and save the selected parameters (8).

S/N: a unique serial number of the device.

It is displayed in the name of the Master wireless access point and is stated on the unit control board.

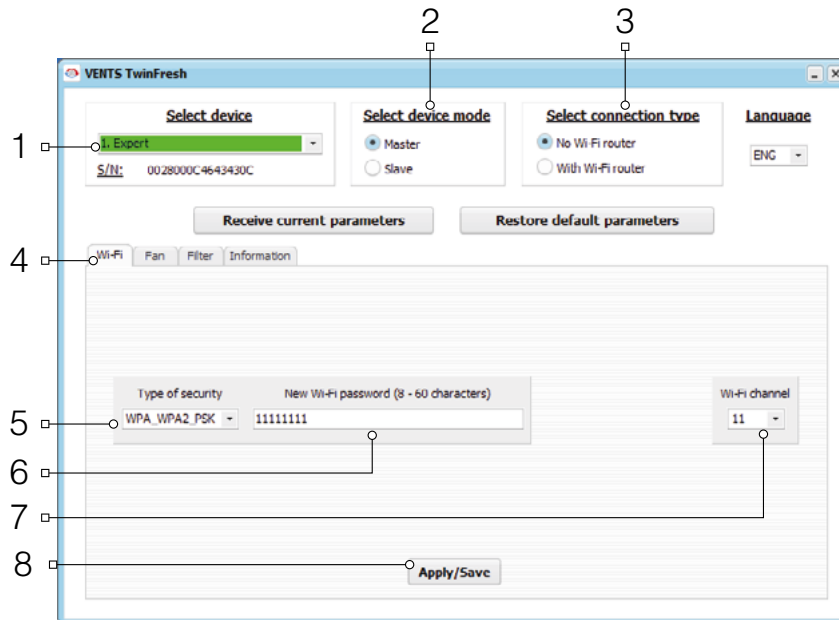

CONFIGURING THE UNIT IN SLAVE MODE ACCORDING TO THE DIAGRAM NO. 1

- Start the software at your PC to set up the unit.
- Connect the unit and PC using a USB to mini USB cable.
- Select a required ventilator from the list (1).
- Select **Slave** for required device mode (2).
- Select **No Wi-Fi router** for the connection type (3).
- Open the tab **Wi-Fi** (4)
- Press **Search Wi-Fi** for the Master unit (5). It is an optional requirement.
- Enter or select from the list the name of a wireless access point of the Master unit (6). The Wi-Fi name must be as follows: TwinFresh: + 16 characters of the serial number of the Master unit as stated on the control board.

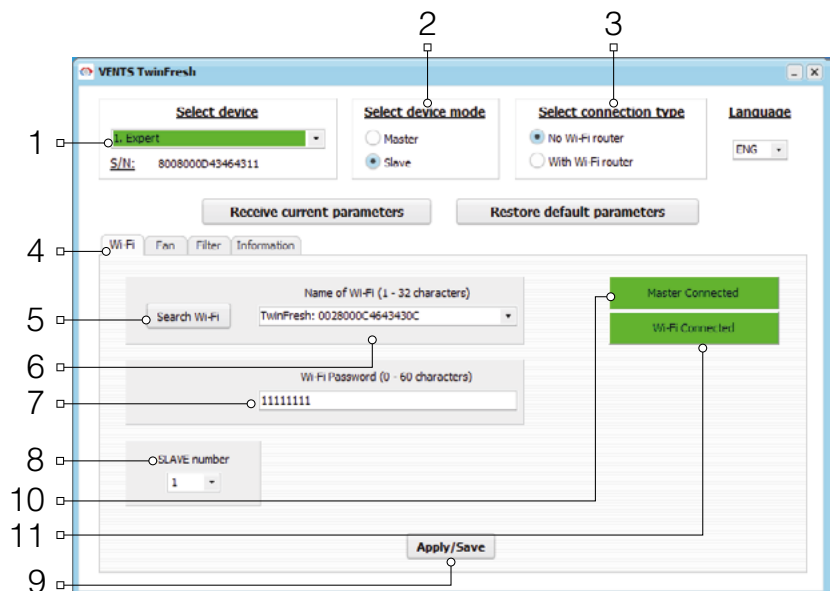

- Enter the Wi-Fi password of the Master unit (7). Wi-Fi password by default: 11111111.
- Set a unique number for each Slave unit (8) from 1 to 32 in the consequent order.
- Apply and save the selected parameters (9).
- If all the parameters are entered correct and the Master unit is turned on, within 10 seconds the tab (10) is displayed as **Master connected** and the tab (11) as **Wi-Fi connected**.

CONFIGURING THE UNIT IN MASTER MODE ACCORDING TO THE DIAGRAM NO. 2

- Start the software at your PC to set up the unit.
- Connect the unit and PC using a USB to mini USB cable.
- Select a required ventilator from the list (1).
- Select **Master** for required device mode (2).
- Select **with Wi-Fi router** for the connection type (3).
- Open the tab **Wi-Fi** (4)
- Press **Search Wi-Fi** (5). It is an optional requirement.
- Enter or select from the list the name of a wireless access point of the router (6).
- Enter Wi-Fi password for the router (7).
- Set a free IP address for the Master unit (8). The IP address must match the current network and be unique. Detection of a free IP address is described below.

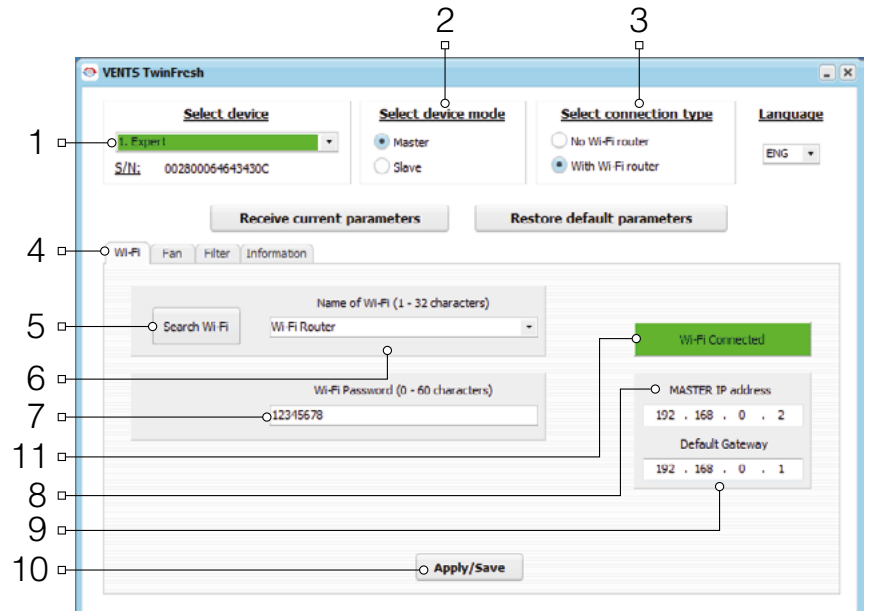

- Apply «**Standard gateway**» for the Master unit (9). It must match the IP-address of the router. This parameter enables coordinated operation of the ventilation unit with a cloud server through internet.
- Apply and save the selected parameters (10).
- If all the parameters are entered correct and the wireless access point is turned on, within 10 seconds the tab (11) is displayed as **Wi-Fi connected**.

Detection of a free IP address for the Master unit and standard gateway address is as follows:

1. Open the window of the command line: press combination Win+R and enter «cmd» in the appeared window «Run», then press **Enter**.
2. Select the command «**ipconfig**» in the appeared window and press **Enter**.
3. The line «**Basic gateway**» indicates the router IP-address. Example: «Basic gateway : 192.168.0.1».
4. Enter this address in the field «**Basic gateway**» (9) in the program for setup of the ventilation unit.
5. Detect a free IP address for the Master unit:
 - enter the command «**ping**» in the command line, IP-address of the router, change the fourth address field from 1 to 254 and press **Enter** until the line «**This unit is not available**» appears. Example: «ping 192.168.0.2»+»Enter».
6. Enter the selected available address in the field «**Master IP address**» for setup of the ventilation unit.

CONFIGURING THE UNIT IN SLAVE MODE ACCORDING TO THE DIAGRAM NO. 2

- Start the software at your PC to set up the unit.
- Connect the ventilation unit to PC using a USB to mini USB cable.
- Select a required device from the dropdown list (1).
- Select **Slave** for required device mode (2).
- Select **With Wi-Fi router** for the connection type (3).
- Open the tab **Wi-Fi** (4)
- Press **Search Wi-Fi** (5). It is an optional requirement.
- Enter or select from the list the name of a wireless access point of the router (6).
- Enter Wi-Fi password for the router (7).
- Set a unique number for each Slave unit (8) from 1 to 32 in the consequent order.
- Check the busy numbers using the installed mobile application, see page 22.
- Enter the IP address of the Master unit (10) for the Slave unit to be connected.
- Set the Slave IP address (9). It is an optional requirement.
 - Set **DHCP** DHCP to enable automatic assigning of the IP address during connection to router.
 - Set **Static** to enable manual assigning of the IP address for the Slave unit. The assigned address must be consistent with the current network and be unique. Detection of a free IP address is described below.
- Apply and save the selected parameters (11).
- If all the parameters are entered correct and the Master unit is turned on, within 10 seconds the tab (12) is displayed as **Master connected** and the tab (13) as **Wi-Fi connected**.

Detection of a free IP address for the Slave unit is as follows:

1. Open the window of the command line: press combination Win+R and enter «cmd» in the appeared window «Run», then press **Enter**.
2. Select the command «**ipconfig**» in the appeared window and press **Enter**.
3. The line «**Basic gateway**» indicates the router IP-address. Example: «Basic gateway : 192.168.0.1».
4. Detect a free IP address for the Slave unit: enter the command «**ping**» in the command line, IP address of the router, change the fourth address field from 1 to 254 and press **Enter** until the line «**Set unit is not available**» appears. Example: «ping 192.168.0.3»+»Enter».
5. Enter the selected available address in the field «**Master IP address**» for setup of the ventilation unit.

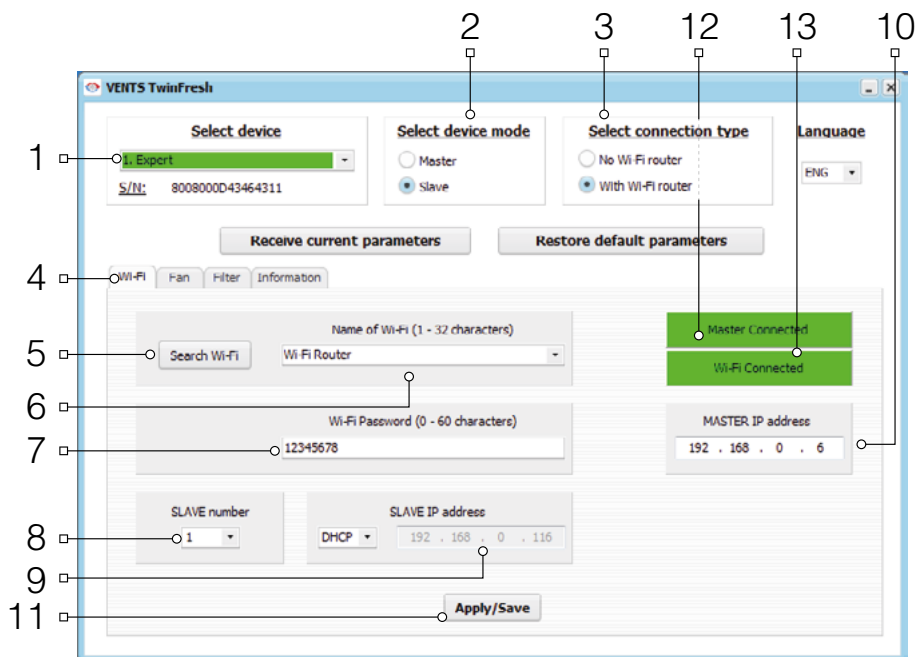

CONNECTION OF A MOBILE DEVICE TO THE UNIT ACCORDING TO THE DIAGRAM NO. 2

- Install the application on your mobile device.
- Connect the Master unit with configurations according to the diagram No. 2.
- Activate Wi-Fi in the system menu of the mobile device.
- Connect to a wireless access point as follows:
 - Set the installed mobile application.
 - In the application menu, open the connection page and create a new connection.

Manual connection:

- Add a new connection.
- Enter the connection name.
- Enter the Master IP address.
- Confirm.

Automatic connection:

- Search new (Master) units.
- Connect the mobile device to the detected Master unit displayed as **New**.
- Enter the connection name.
- Confirm.

MASTER UNIT DEMO MODE

This mode is for demonstration of the unit operation in a sales shop. No connection to a PC is required. In demo mode the unit operates in Master mode with its own wireless access point. Only one Slave unit and three mobile devices may be connected to the wireless access point. However it is recommended to connect one mobile device only.

Several parallel connected units in Master mode will have the same name and it may result in their conflict during connection of Slave units in demo mode.

Master unit Wi-Fi name: TwinFresh.

Master unit Wi-Fi password: 11111111.

SLAVE UNIT DEMO MODE

This mode is for demonstration of the unit operation in a sales shop.

It is easy to use because of the quick configuration and requires no connection to a PC.

The ventilation unit operates in Slave mode and is automatically connected to a wireless connection point of the Master unit set for demo mode.

AIR FLOW BLOCKING FOR TwinFresh Expert RW1

Press the front panel to close the air duct. The fan turns off automatically. The unit functionality is not changed. To open the air duct, pull the front panel while holding the special recesses. The fan starts operating according to the actual speed setting.

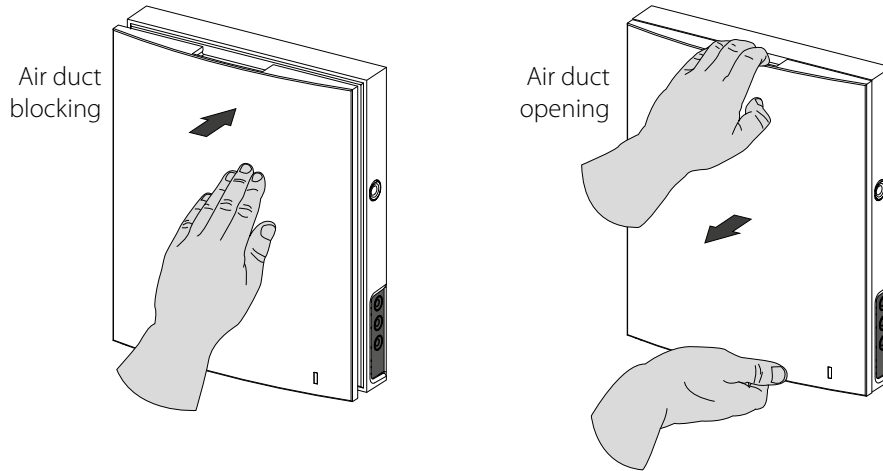

The light operating indicator is located on the front panel. During the dark time the indicator light intensity drops down.

AIR FLOW BLOCKING FOR THE TwinFresh Expert Duo RW1

Press the side tabs to detach the front part of the indoor unit from its back part and close the air duct. Then open the latches and remove the front part of the front panel.

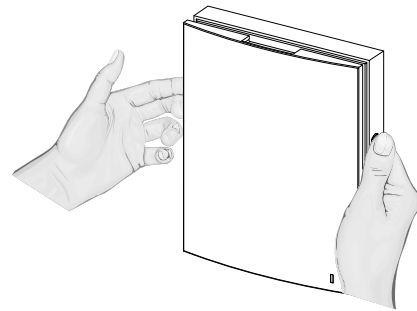

Remove the air flow separator by pulling one of the side clamps. Install the front part of the front panel and press it gently to close the air duct. The fan turns off automatically. The unit functionality is not changed. Open the air duct in the reverse order. The fan starts operating according to the actual speed setting.

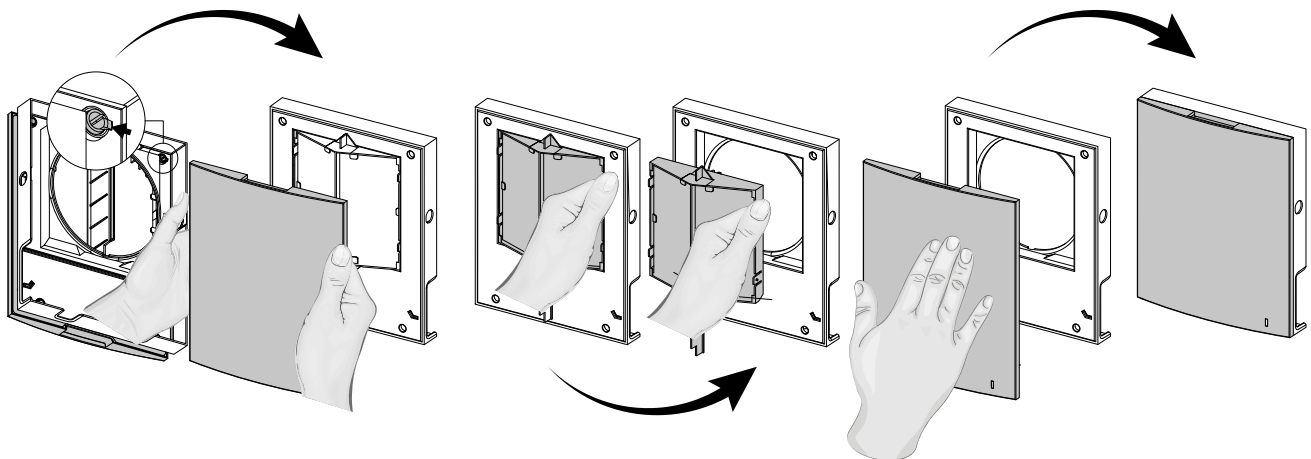

The light operating indicator is located on the front panel. During the dark time the indicator light intensity drops down.

TECHNICAL MAINTENANCE

Maintenance of the ventilator means regular cleaning of the ventilator surfaces of dust and cleaning and replacement of the filters. To access the basic assembly units follow the steps:

Turn off the ventilator using the remote control or the buttons on the indoor unit. Then turn the power completely off.

TwinFresh Expert RW1-50

1. Press the latches on the side of the indoor control unit to take off the front part.

Please make sure the louvre actuator rod is in lower position during re-installation of the front panel.

If the actuator rod is up, please wait for about 2 minutes until it goes down.

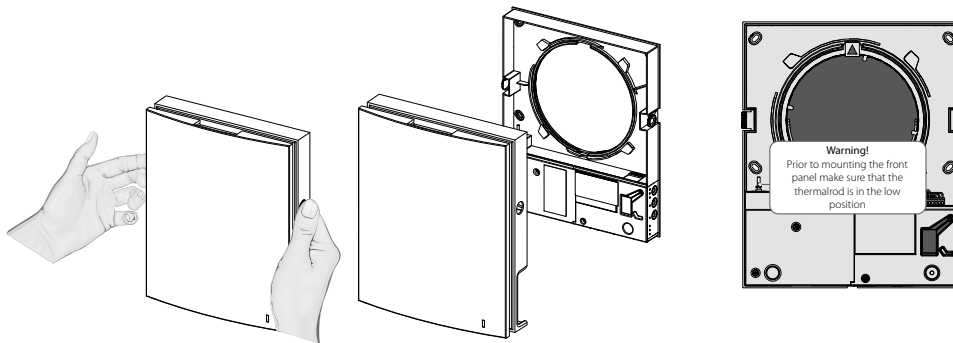

TwinFresh Expert RW1-50

1. Press the latches on the side of the indoor control unit to take off the front part.

Then remove the front panel from the front part of the indoor unit by carefully undoing the latches.

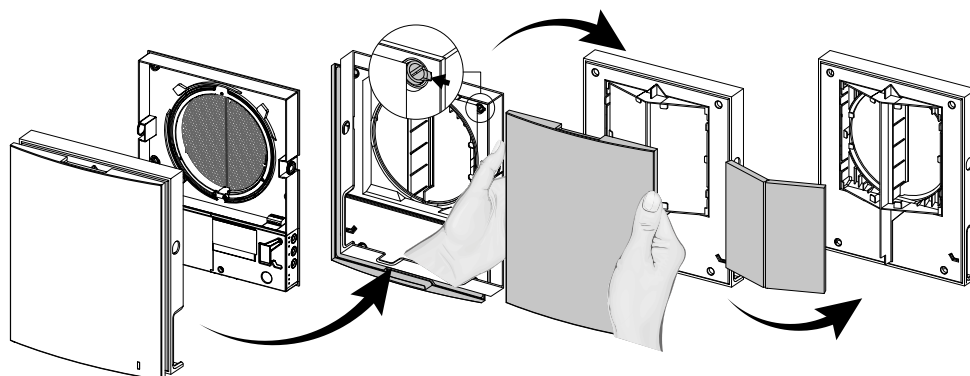

2. Disconnect the connector from the circuit board.

While removing the connector do not pull the cable. Uplift it with a flat screw driver of a respective size.

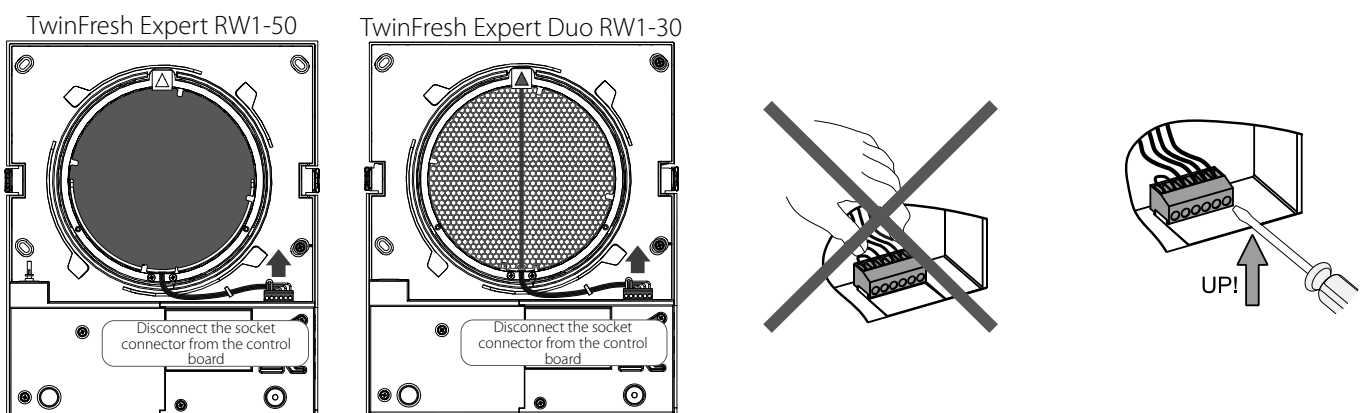

3. Pull the cord to remove the cartridge from the air duct.

TwinFresh Expert RW1-50

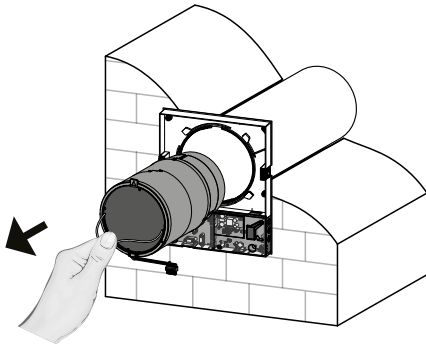

TwinFresh Expert Duo RW1-30

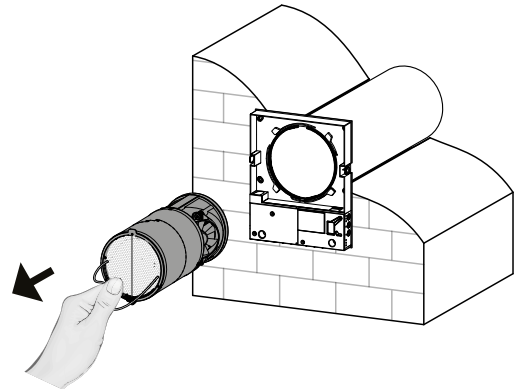

Clean the filters as they get clogged, but not less than once in three months.

- Upon elapse of the set time period (factory setting 90 days) the filter replacement indicator (Filter) starts glowing. Resetting of the filter timer settings is performed with the DIP switch on the control board or using the application at your PC, see page 18 or mobile device.
- Wash the filters and let those dry out completely. Install the dry filters in their place and assemble the unit in the reverse order.
- Vacuum cleaning is allowed.
- The filter rated service life is 3 years.

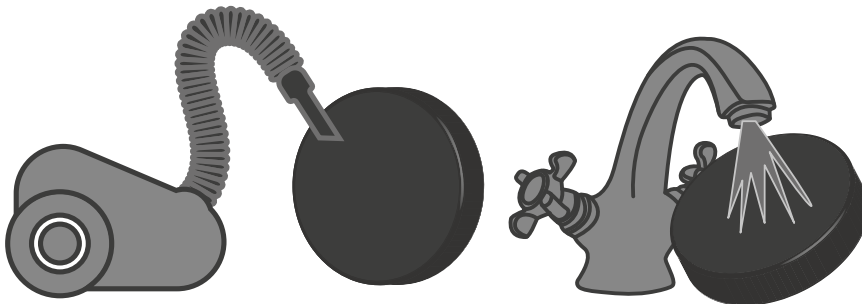

Some dust may accumulate on the heat exchanger block even in case of regular maintenance of the filters.

- Clean the regenerator regularly to ensure its high heat recovery efficiency.
- Vacuum clean the regenerator not less than once a year.

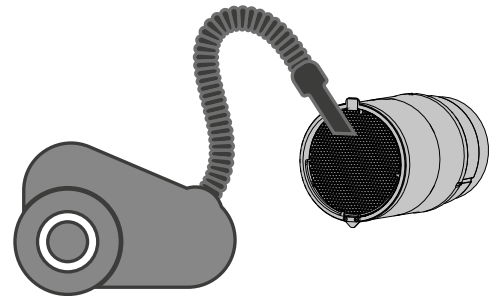

4. Replacement of the remote control battery (if necessary).

In case of a long operation of the remote control the battery must be replaced.

No response of the unit for pressing the remote control buttons indicates the need to replace the battery.

The battery type is CR2025.

Remove the holder with the battery from the lower part of the remote control.

Replace the battery and install the holder with a new battery back to the remote control.

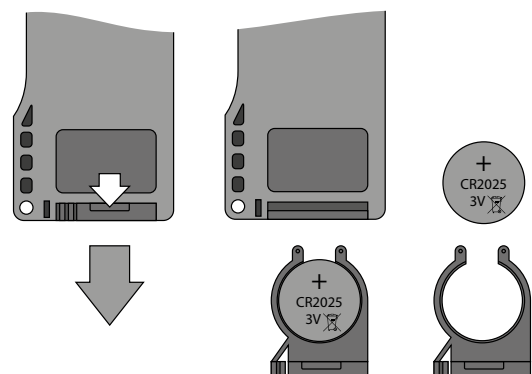

TROUBLESHOOTING

POSSIBLE REASONS AND TROUBLESHOOTING

Problem	Possible reasons	Troubleshooting
When switching on the ventilator the fan does not start.	No power supply.	Make sure the power supply line is connected correctly, otherwise troubleshoot the connection error.
	The motor is jammed, the impeller blades are soiled.	Turn the ventilator off. Troubleshoot the motor jam and the impeller clogging. Clean the blades. Turn the ventilator on.
Circuit breaker tripping during the ventilation unit start-up.	Overcurrent as a result of short circuit in the electric line.	Turn the ventilator off. Contact the Seller for further information.
Low air flow.	Low set fan speed.	Set higher speed.
	The filters, the fan or the regenerator are clogged.	Clean or replace the filter. Clean the fan and the regenerator.
Noise, vibration.	The impeller is clogged.	Clean the impeller.
	Loose screw connection of the unit casing or the outer ventilation hood.	Tighten the screws of the ventilator or the outer ventilation hood.

STORAGE AND TRANSPORTATION REGULATIONS

- Store the unit in the manufacturer's original packaging box in a dry closed ventilated premise with temperature range from +5 °C to +40 °C and relative humidity up to 70 %.
- Storage environment must not contain aggressive vapors and chemical mixtures provoking corrosion, insulation, and sealing deformation.
- Use suitable hoist machinery for handling and storage operations to prevent possible damage to the unit.
- Follow the handling requirements applicable for the particular type of cargo.
- The unit can be carried in the original packaging by any mode of transport provided proper protection against precipitation and mechanical damage. The unit must be transported only in the working position.
- Avoid sharp blows, scratches, or rough handling during loading and unloading.
- Prior to the initial power-up after transportation at low temperatures, allow the unit to warm up at operating temperature for at least 3-4 hours.

MANUFACTURER'S WARRANTY

Production meets standard operating requirements in the USA and Canada.

Vents US warrants to the original purchaser of the unit that it will be free from defects in materials or workmanship for a period of 24 months from the date of original purchase. The Vents US warrants to the original purchaser of the unit that the integrated control unit will be free from defects in materials and workmanship for a period of 24 months from the date of original purchase.

THERE ARE NO OTHER WARRANTIES, EXPRESS OR IMPLIED, INCLUDING, BUT NOT LIMITED TO, IMPLIED WARRANTIES OF MERCHANTABILITY OR FITNESS FOR A PARTICULAR PURPOSE.

During the stated warranty period, Vents US will, at its option, repair or replace, without charge, any product or part which is found to be defective under normal use and service. This warranty does not cover (a) normal maintenance and normal service or (b) any products or parts which have been subject to misuse, negligence, accident, improper maintenance or repair (other than by Vents US), faulty installation or installation contrary to recommended installation instructions. Labor to remove and replace products is not covered. The duration of any implied warranty is limited to the time period specified for the express warranty. Some states do not allow limitations on how long an implied warranty lasts, so the above limitation may not apply to you.

VENTS US OBLIGATION TO REPAIR OR REPLACE, AT VENTS US OPTION, SHALL BE THE PURCHASER'S SOLE AND EXCLUSIVE REMEDY UNDER THIS WARRANTY. VENTS US SHALL NOT BE LIABLE FOR INCIDENTAL, CONSEQUENTIAL OR SPECIAL DAMAGES ARISING OUT OF OR IN CONNECTION WITH PRODUCT USE OR PERFORMANCE.

Some states do not allow the exclusion or limitations of incidental or consequential damages, so the above limitation or exclusion may not apply to you. This warranty gives you specific legal rights, and you may also have other rights which vary from state to state. This warranty supersedes all prior warranties. If proof of sales date is absent, warranty period is calculated from the production date. The unit can be exchanged at the following address:

Vents-US
400 Murray Road, Cincinnati, OH 45217, USA
Tel: 1-888-640-0925, 513-583-5786, Fax: 513-268-4597
E-mail: support@ventsus.com
www.vents-us.com

Please follow guidelines in this manual for product problem-free operation.



FOLLOWING THE REGULATIONS STIPULATED HEREIN WILL ENSURE A LONG AND TROUBLE-FREE OPERATION OF THE UNIT



USER'S WARRANTY CLAIMS SHALL BE SUBJECT TO REVIEW ONLY UPON PRESENTATION OF THE UNIT, THE PAYMENT DOCUMENT AND THE USER'S MANUAL WITH THE PURCHASE DATE STAMP

CERTIFICATE OF ACCEPTANCE

Unit Type	Single-room reversible energy recovery ventilator
Model	
Serial Number	
Manufacture Date	
Quality Inspector's Stamp	

SELLER INFORMATION

Seller	
Address	
Phone Number	
E-mail	
Purchase Date	
This is to certify acceptance of the complete unit delivery with the user's manual. The warranty terms are acknowledged and accepted.	
Customer's Signature	

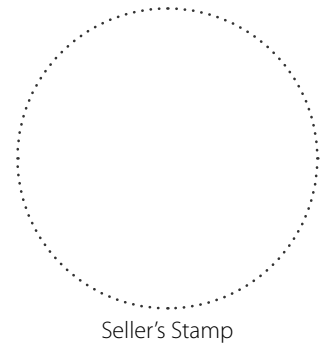

INSTALLATION CERTIFICATE

The _____ unit is installed pursuant to the requirements stated in the present user's manual.	
Company name	
Address	
Phone Number	
Installation Technician's Full Name	
Installation Date:	Signature:
The unit has been installed in accordance with the provisions of all the applicable local and national construction, electrical and technical codes and standards. The unit operates normally as intended by the manufacturer.	
Signature:	

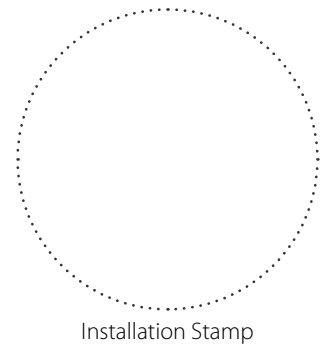

WARRANTY CARD

Unit Type	Single-room reversible energy recovery ventilator
Model	
Serial Number	
Manufacture Date	
Purchase Date	
Warranty Period	
Seller	

