

## VCN SERIES

For High Static Pressure Application



The VENTS VCN outdoor wall-mounted exhaust fan is ideal for commercial applications where powerful exhaust is required and the space is limited. It allows powerful air extraction from one or more points and is suitable for connection to long duct runs. Fans have a casing made of steel with polymer coating and insect proof mesh. Motors are supplied with automatic reset thermal protection, and are equipped with ball bearings for longer service life (40,000 hrs). The VENTS VCN series fans have been specifically designed for simple installation and many years of maintenance free operation. The casing is removable for immediate access to the motor and wiring connections. VENTS VCN sizes range from 4" to 8", with airflows ranging up to 306 CFM. Smooth and reliable operation are the attributes of VENTS VCN centrifugal fans.

### APPLICATION

- Bathroom exhaust
- Kitchen ventilation
- Workshops & smoking areas
- Offices
- Bars & Restaurants
- Warehouses

### BENEFITS

- High airflow and static pressure applications
- Efficient operation without vibration
- Durable and corrosion resistant casing
- Durable, external rotor motor design
- Permanently lubricated ball bearing motors for maintenance-free operation
- Automatic reset thermal overload protection
- Casing can be easily removed for cleaning
- Rated for continuous operation
- Optimized efficiency, low maintenance costs
- ETL listed

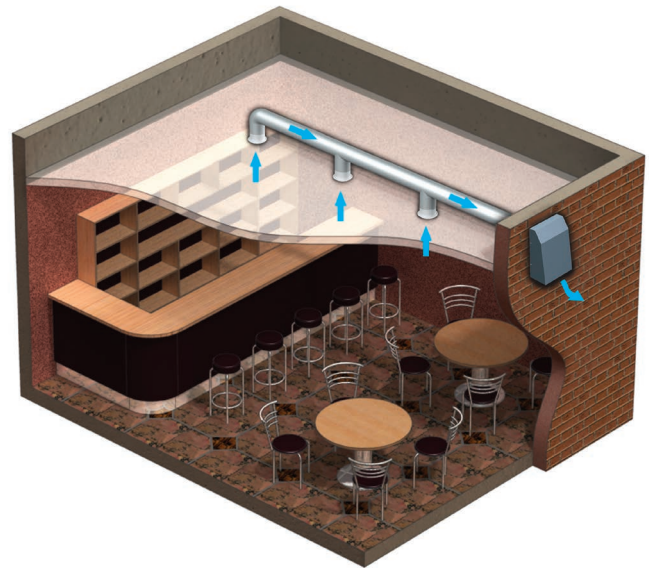

Bar ventilation example

**DIMENSIONS**

Model	Measurements [in.]				lbs
	ØD	H	B	L	
<b>VCN 100</b>	3 15/16"	14"	10 1/4"	5 7/16"	9.0
<b>VCN 125</b>	4 15/16"	14"	10 1/4"	5 7/16"	9.0
<b>VCN 150</b>	5 7/8"	15 3/4"	11 13/16"	5 7/16"	9.9
<b>VCN 200</b>	7 7/8"	15 3/4"	11 13/16"	5 7/16"	9.9

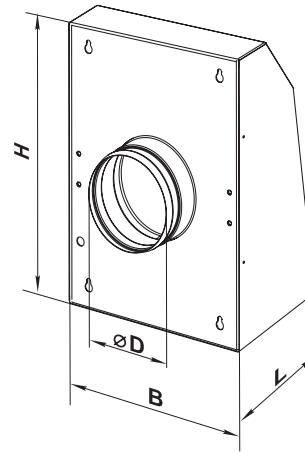
**PERFORMANCE**

Model	Duct dia	CFM vs. Static Pressure (Ps) in WG					Sones	RPM*	Watts*
		0"	0.25"	0.5"	1.0"	1.5"			
<b>VCN 100</b>	4"	238	223	204	134	30	720	3100	108
<b>VCN 125</b>	5"	248	231	213	146	25	710	2950	108
<b>VCN 150</b>	6"	302	286	256	159	37	7.84	2250	109
<b>VCN 200</b>	8"	306	291	258	148	9	8.10	2300	106

\* The parameters RPM, Watts are indicated at 0.2 in WG static pressure.

**SPECIFICATION**

Voltage: 120V 60Hz

Motor: Single-phase external rotor motor with backward curved centrifugal impellers

Duct compatibility: Ø 4", 5", 6", 8"

Airflow capacity: up to 306 CFM

Sones: 7.1 – 8.1

Power consumption: 106 – 109 W

Suitable for working airstreams up to 113° F

IP X4 protection

Thermal overload protection