

VK SERIES

For High Static Pressure Application



DESCRIPTION

The VENTS VK Series duct mounted centrifugal inline fans are suitable for a wide range of residential and commercial exhaust or supply air applications, such as bathrooms, kitchens, restaurants or equipment cooling.

The VENTS VK inline fans assure efficient and reliable operation. The fans are fitted with backward curved centrifugal impeller driven by powerful sealed external rotor motor with lifelong bearings and thermal protection. This powerful combination enables the VENTS VK fans to deliver exceptional airflow performances even in high static pressure systems. The fans' casing is made of high quality, UV-resistant plastic (flame rating – 5VA). The VENTS VK fans are specially designed for simple installation and years of maintenance free operation. The VENTS VK fans are supplied with an easy to fit mounting bracket and can be mounted at any angle and at any point along the duct.

APPLICATIONS

- Bathroom exhaust
- Kitchen ventilation
- Living area
- Whole house ventilation
- Duct boosting
- Workshops & smoking areas

BENEFITS

- Sizes available 4" - 12"
- High static pressure applications
- Backward curved centrifugal impeller
- Quiet external rotor motor with thermal overload protection
- Ideal for long duct runs
- Quiet and powerful
- Vibration free operation
- Energy efficient
- Maintenance free
- Easy installation
- Corrosion resistant
- UV resistant, UL94 certified plastic
- Pre-wired and supplied with mounting bracket for easy installation
- ETL listed
- HVI certified



Tel: 888-640-0925
Fax: 513-268-4597

Sales@ventsus.com
VentsUS.com
400 Murray Rd,
Cincinnati, OH 45217

HVI
MEMBER™

HVI
CERTIFIED

ETL
LISTED
Intertek

HARDI

DIMENSIONS

Model	Measurements [in.]							lbs
	ØD	ØD1	B	L	L1	L2	L3	
VK 100	3 15/16"	9 13/16"	10 5/8"	9 1/16"	1 3/16"	1 1/16"	1 3/16"	4.7
VK 125	4 15/16"	9 13/16"	10 5/8"	8 11/16"	1 3/16"	1 1/16"	1 3/16"	4.9
VK 150 E	5 7/8"	11 13/16"	12 3/16"	11 1/4"	1 3/16"	1 3/16"	1 3/16"	5.7
VK 150	5 7/8"	11 13/16"	12 3/16"	11 1/4"	1 3/16"	1 3/16"	1 3/16"	5.7
VK 200 E	7 7/8"	13 3/8"	13 15/16"	10 7/8"	1 3/16"	1 3/16"	1 9/16"	8.8
VK 200	7 7/8"	13 3/8"	13 15/16"	10 7/8"	1 3/16"	1 3/16"	1 9/16"	8.8
VK 250	9 13/16"	13 3/8"	13 15/16"	10 7/8"	1 3/16"	1 3/16"	1 9/16"	9.9
VK 315	12 3/8"	15 3/4"	16 5/16"	16 5/16"	1 9/16"	2 3/16"	1 9/16"	11.2

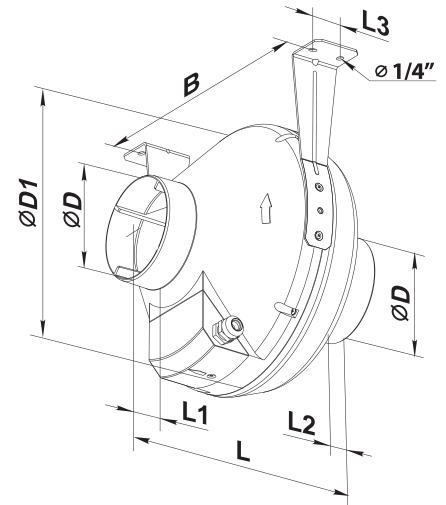
PERFORMANCE

Model	Duct dia	Energy Star compliance	Sones	RPM*	Watts*	Amps*	CFM*	CFM vs. Static Pressure (Ps) in WG											Max Ps. in WG	Volts
								0"	0.1"	0.2"	0.3"	0.4"	0.5"	0.6"	0.7"	0.8"	0.9"	1.0"		
VK 100	4"	no	2.3	2872	88.5	0.75	176**	193	184	176**	167	159**	148	140**	131	122	114	105	2.1	120
VK 125	5"	no	2.3	2960	114	0.95	214	235	220	214	198	185	178	167	156	145	134	123	2.4	120
VK 150	6"	no	2.7	2785	93	0.77	290**	321	307	290**	272	255**	237	222**	206	193	175	159	1.8	120
VK 150 E	6"	yes	3.8	3000	51	0.98	200	228	215	200	190	170	151	135	115	90	70	44	1.18	120
VK 200	8"	no	3.5	2781	149	1.25	520**	562	536	520**	501	472**	451	424**	397	372	347	329	2.5	120
VK 200 E	8"	yes	3.9	3275	88	0.73	380	418	400	380	360	340	316	290	275	250	225	200	1.66	120
VK 250	10"	no	4.3	2523	266	2.25	620**	683	653	620**	588	551**	518	487**	453	423	394	368	3.1	120
VK 315	12"	no	4.1	2641	269	2.25	770**	871	825	770**	736	683**	645	569**	515	476	430	388**	2.8	120

* The parameters Volts, Watts, Amps are indicated at 0.2 in WG static pressure
 ** HVI rated

SPECIFICATION

Voltage: 120 V, 60 Hz

Motor: Single-phase external rotor motor with backward curved centrifugal impellers

Duct compatibility: Ø 4", 5", 6", 8", 10", 12"

Airflow capacity: up to 871 CFM

Sones: 2.3 – 4.3

Power consumption: 51 – 269 W

Suitable for working airstreams up to 149 °F

IPX4 protection

Thermal overload protection

Mounting bracket and power cord included