

DESCRIPTION

VENTS VK inline fans assure efficient and reliable operation. The VENTS VK fans are specially designed for simple installation and years of maintenance free operation. The VENTS VK fans are supplied with an easy to fit mounting bracket and can be mounted at any angle and at any point along the duct. Suitable for wide range diameter sizes (from 4" to 12").

DESIGN

The fans' casing is made of high quality, UV-resistant plastic (UL94 certified plastic).

MOTOR

The fan is fitted with backward curved centrifugal impeller driven by powerful sealed external rotor motor with lifelong bearings and thermal protection.

SUITABLE FOR

The fans are suitable for a wide range of residential and commercial exhaust or supply air applications, such as bathrooms, kitchens, restaurants or equipment cooling.

DIMENSIONS

Model	Measurements [in.]							lbs
	ØD	ØD1	B	L	L1	L2	L3	
VK 250	9 13/16"	13 3/8"	13 15/16"	10 7/16"	1 3/16"	1 3/16"	1 9/16"	9.9

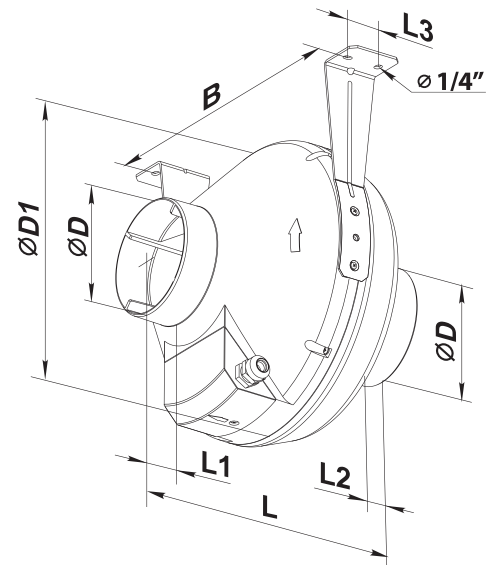

PERFORMANCE

Model	Duct dia	Energy Star compliance	Sones	RPM*	Watts*	Amps*	CFM*	CFM vs. Static Pressure (Ps) in WG											Max Ps. in WG	Volts
								0"	0.1"	0.2"	0.3"	0.4"	0.5"	0.6"	0.7"	0.8"	0.9"	1.0"		
VK 250	10"	no	4.3	2523	266	2.25	620**	683	653	620**	588	551**	518	487**	453	423	394	368	3.1	120

* The parameters Volts, Watts, Amps are indicated at 0.2 in WG static pressure

** HVI rated

MODEL	QUANTITY	COMMENTS	PROJECT
			location:
			architect:
			engineer:
			contractor:
			submitted by:

Tel: 888-640-0925
Fax: 513-268-4597

Sales@ventsus.com
VentsUS.com
400 Murray Rd,
Cincinnati, OH 45217

HARDI

2024-06