

DESCRIPTION

VENTS VK inline fans assure efficient and reliable operation. The VENTS VK fans are specially designed for simple installation and years of maintenance free operation. The VENTS VK fans are supplied with an easy to fit mounting bracket and can be mounted at any angle and at any point along the duct. Suitable for wide range diameter sizes (from 4" to 12").

DESIGN

The fans' casing is made of high quality, UV-resistant plastic (UL94 certified plastic).

MOTOR

The fan is fitted with backward curved centrifugal impeller driven by powerful sealed external rotor motor with lifelong bearings and thermal protection.

SUITABLE FOR

The fans are suitable for a wide range of residential and commercial exhaust or supply air applications, such as bathrooms, kitchens, restaurants or equipment cooling.

DIMENSIONS

Model	Measurements [in.]							lbs
	ØD	ØD1	B	L	L1	L2	L3	
VK 100	3 15/16"	9 13/16"	10 5/8"	9 1/16"	1 3/16"	1 1/16"	1 3/16"	4.7
VK 125	4 15/16"	9 13/16"	10 5/8"	8 11/16"	1 3/16"	1 1/16"	1 3/16"	4.9
VK 150 E	5 7/8"	11 13/16"	12 3/16"	11 1/4"	1 3/16"	1 3/16"	1 3/16"	5.7
VK 150	5 7/8"	11 13/16"	12 3/16"	11 1/4"	1 3/16"	1 3/16"	1 3/16"	5.7
VK 200 E	7 7/8"	13 3/8"	13 15/16"	10 7/8"	1 3/16"	1 3/16"	1 9/16"	8.8
VK 200	7 7/8"	13 3/8"	13 15/16"	10 7/8"	1 3/16"	1 3/16"	1 9/16"	8.8
VK 250	9 13/16"	13 3/8"	13 15/16"	10 7/16"	1 3/16"	1 3/16"	1 9/16"	9.9
VK 315	12 3/8"	15 3/4"	16 5/16"	16 5/16"	1 9/16"	2 3/16"	1 9/16"	11.2

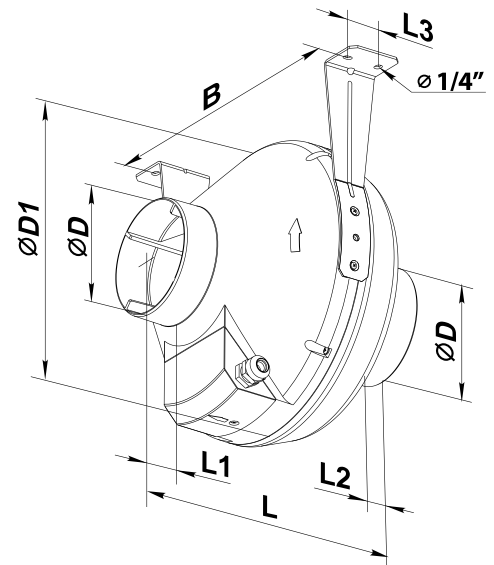

PERFORMANCE

Model	Duct dia	Energy Star compliance	Sones	RPM*	Watts*	Amps*	CFM*	CFM vs. Static Pressure (Ps) in WG											Max Ps. in WG	Volts
								0"	0.1"	0.2"	0.3"	0.4"	0.5"	0.6"	0.7"	0.8"	0.9"	1.0"		
VK 100	4"	no	2.3	2872	88.5	0.75	176**	193	184	176**	167	159**	148	140**	131	122	114	105	2.1	120
VK 125	5"	no	2.3	2960	114	0.95	214	235	220	214	198	185	178	167	156	145	134	123	2.4	120
VK 150	6"	no	2.7	2785	93	0.77	290**	321	307	290**	272	255**	237	222**	206	193	175	159	1.8	120
VK 150 E	6"	yes	3.8	3000	51	0.98	200	228	215	200	190	170	151	135	115	90	70	44	1.18	120
VK 200	8"	no	3.5	2781	149	1.25	520**	562	536	520**	501	472**	451	424**	397	372	347	329	2.5	120
VK 200 E	8"	yes	3.9	3275	88	0.73	380	418	400	380	360	340	316	290	275	250	225	200	1.66	120
VK 250	10"	no	4.3	2523	266	2.25	620**	683	653	620**	588	551**	518	487**	453	423	394	368	3.1	120
VK 315	12"	no	4.1	2641	269	2.25	770**	871	825	770**	736	683**	645	569**	515	476	430	388**	2.8	120

* The parameters Volts, Watts, Amps are indicated at 0.2 in WG static pressure
 ** HVI rated

MODEL	QUANTITY	COMMENTS	PROJECT
			location:
			architect:
			engineer:
			contractor:
			submitted by:

Tel: 888-640-0925
 513-583-5786

Sales@vents-us.com
 Vents-US.com
 400 Murray Rd,
 Cincinnati, OH 45217