

VK

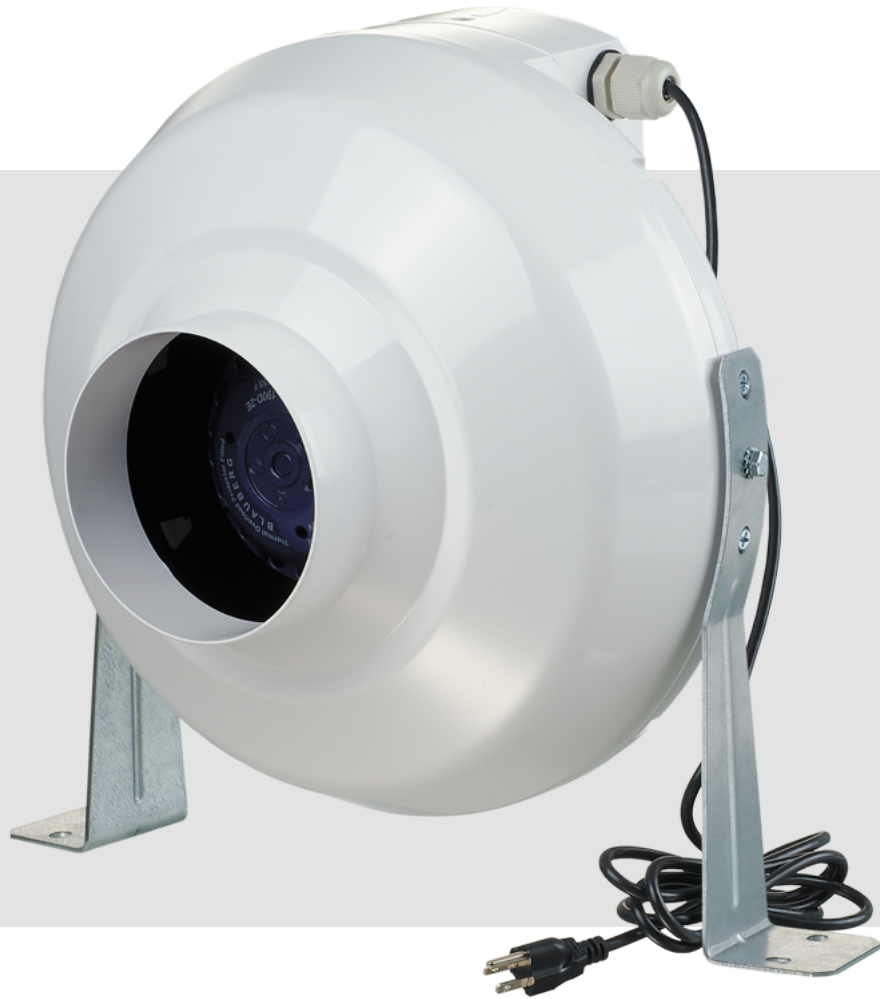

Centrifugal fan

CONTENTS

Safety requirements.....	2
Purpose.....	5
Delivery set.....	5
Designation key.....	5
Technical data.....	6
Design and operating principle	7
Mounting and set-up.....	8
Connection to power mains	10
Technical maintenance.....	12
Storage and transportation regulations.....	13
Manufacturer's warranty.....	14
Certificate of acceptance.....	15
Seller information	15
Installation certificate.....	15
Warranty card.....	15

This user's manual is a main operating document intended for technical, maintenance, and operating staff.

The manual contains information about purpose, technical details, operating principle, design, and installation of the VK unit and all its modifications.

Technical and maintenance staff must have theoretical and practical training in the field of ventilation systems and should be able to work in accordance with workplace safety rules as well as construction norms and standards applicable in the territory of the country.

SAFETY REQUIREMENTS

This unit is not intended for use by persons (including children) with reduced physical, sensory or mental capabilities, or lack of experience and knowledge, unless they have been given supervision or instruction concerning use of the unit by a person responsible for their safety. Children should be supervised to ensure that they do not play with the unit.

This appliance can be used by children aged from 8 years and above and persons with reduced physical, sensory or mental capabilities or lack of experience and knowledge if they have been given supervision or instruction concerning use of the appliance in a safe way and understand the hazards involved.

Cleaning and user maintenance shall not be done by children without supervision.

Children shall not play with the appliance.

Connection to the mains must be made through a disconnecting device, which is integrated into the fixed wiring system in accordance with the wiring rules for design of electrical units, and has a contact separation in all poles that allows for full disconnection under overvoltage category III conditions.

If the supply cord is damaged, it must be replaced by the manufacturer, its service agent, or similarly qualified persons in order to avoid a safety hazard.

Precautions must be taken to avoid the back-flow of gases into the room from the open flue of gas or other fuel-burning appliances.

The appliance may adversely affect the safe operation of appliances burning gas or other fuels (including those in other rooms) due to back flow of combustion gases. These gases can potentially result in carbon monoxide poisoning. After installation of the unit the operation of flued gas appliances should be tested by a competent person to ensure that back flow of combustion gases does not occur.

CAUTION: In order to avoid a safety hazard due to inadvertent resetting of the thermal cut-out, this unit must not be supplied through an external switching device, such as a timer, or connected to a circuit that is regularly switched on and off by the utility.

Ensure that the unit is switched off from the supply mains before removing the guard.

WARNING: If there are any unusual oscillating movements, immediately stop using the unit and contact the manufacturer, its service agent or suitably qualified persons.

The replacement of parts of the safety suspension system device shall be performed by the manufacturer, its service agent or suitably qualified persons.

Precautions must be taken to avoid the back-flow of gases into the room from the open flue of gas or other fuel-burning appliances.

The appliance may adversely affect the safe operation of appliances burning gas or other fuels (including those in other rooms) due to back flow of combustion gases. These gases can potentially result in carbon monoxide poisoning. After installation of the unit the operation of flued gas appliances should be tested by a competent person to ensure that back flow of combustion gases does not occur.

All operations described in this manual must be performed by qualified personnel only, properly trained and qualified to install, make electrical connections and maintain ventilation units.

Do not attempt to install the product, connect it to the mains, or perform maintenance yourself. This is unsafe and impossible without special knowledge.

Disconnect the power supply prior to any operations with the unit.

All user's manual requirements as well as the provisions of all the applicable local and national construction, electrical, and technical norms and standards must be observed when installing and operating the unit.

Disconnect the unit from the power supply prior to any connection, servicing, maintenance, and repair operations.

Connection of the unit to power mains is allowed by a qualified electrician with a work permit for the electric units up to 1000 V after careful reading of the present user's manual.

Check the unit for any visible damage of the impeller, the casing, and the grille before starting

installation. The casing internals must be free of any foreign objects that can damage the impeller blades.

While mounting the unit, avoid compression of the casing! Deformation of the casing may result in motor jam and excessive noise.

Misuse of the unit and any unauthorised modifications are not allowed.

Do not expose the unit to adverse atmospheric agents (rain, sun, etc.).

Transported air must not contain any dust or other solid impurities, sticky substances, or fibrous materials.

Do not use the unit in a hazardous or explosive environment containing spirits, gasoline, insecticides, etc.

Do not close or block the intake or extract vents in order to ensure the efficient air flow.

Do not sit on the unit and do not put objects on it.

The information in this user's manual was correct at the time of the document's preparation.

The Company reserves the right to modify the technical characteristics, design, or configuration of its products at any time in order to incorporate the latest technological developments.

Never touch the unit with wet or damp hands.

Never touch the unit when barefoot.

BEFORE INSTALLING ADDITIONAL EXTERNAL DEVICES, READ THE RELEVANT USER MANUALS.

- 

THE UNIT MUST NOT BE OPERATED IN KITCHEN PREMISES.
- 

NOT SUITABLE FOR USE WITH SOLID-STATE SPEED CONTROLS
- 

MOTOR IS THERMALLY PROTECTED
- 

FOR INTERIOR USE ONLY
- 

INSTALL IN INTERIOR WALL
- 

THIS DUCT FAN SHALL BE INSTALLED A MINIMUM OF ONE METRE FROM ANY ACCESSIBLE OPENING OF THE DUCT
- 

**THE PRODUCT MUST BE DISPOSED SEPARATELY AT THE END OF ITS SERVICE LIFE.
DO NOT DISPOSE THE UNIT AS UNSORTED DOMESTIC WASTE.**

PURPOSE

The product described herein is a centrifugal inline fan for supply or exhaust ventilation of premises. The fan is designed for connection to \varnothing 4", 5", 6", 8", 10", 12" air ducts.

Transported air must not contain any flammable or explosive mixtures, evaporation of chemicals, sticky substances, fibrous materials, coarse dust, soot and oil particles or environments favourable for the formation of hazardous substances (toxic substances, dust, pathogenic germs).

DELIVERY SET

Name	Number
Fan	1 pc.
Screws and dowels	4 pcs.
Mounting bracket	2 pcs.
User's manual	1 pc.
Packing box	1 pc.

DESIGNATION KEY

VK 100 U

Additional options

E: EnergyStar compliant

U: speed controller with an electronic thermostat and an integrated temperature sensor. Temperature-based operation logic

U1: speed controller with an electronic thermostat and an integrated temperature sensor. Timer-based operation logic

Un: speed controller with an electronic thermostat and an external temperature sensor fixed on a 4-meter cable. Temperature-based operation logic

U1n: speed controller with an electronic thermostat and an external temperature sensor fixed on a 4-meter cable. Timer-based operation logic

U2: speed controller with an electronic thermostat and an integrated temperature sensor. Temperature-based switching on/off

U2n: speed controller with an electronic thermostat and an external temperature sensor fixed on a 4-meter cable. Temperature-based switching on/off

P: integrated smooth speed controller

Air duct diameter [mm]

100; 125; 150; 200; 250; 315

Unit series

VK: Centrifugal fan

TECHNICAL DATA

The fan is designed for indoor application with the ambient temperature ranging from +33 °F up to +104 °F and relative humidity up to 80 %. Hazardous parts access and water ingress protection rating is IPX4.

The unit is rated as a class II electric appliance.

The unit design is constantly being improved, thus some models may be slightly different from those described in this manual.

To comply with the ErP 2018 regulation, a local demand controller and speed controller must be used.

Model	Duct dia	Energy Star compliance	Sones	RPM*	Watts*	Amps*	CFM*	CFM vs. Static Pressure (Ps) in WG											Max Ps, in WG	Volt/Hz
								0	0,1	0,2	0,3	0,4	0,5	0,6	0,7	0,8	0,9	1		
VK 100	4"	no	2,3	2872	88,5	0,75	176**	193	184	176**	167	159**	148	140**	131	122	114	105	2,1	120/60
VK 125	5"	no	2.3	2960	114	-	-	235	-	214	-	-	178	-	-	-	-	123	-	120/60
VK 150	6"	no	2,7	2785	93	0,77	290**	321	307	290**	272	255**	237	222**	206	193	175	159	1,8	120/60
VK 150 E	6"	yes	3,8	3000	51	0,98	200	228	215	200	190	170	151	135	115	90	70	44	1,18	120/60
VK 200	8"	no	3,5	2781	149	1,25	520**	562	536	520**	501	472**	451	424**	397	372	347	329	2,5	120/60
VK 200 E	8"	yes	3,9	3275	88	0,73	380	418	400	380	360	340	316	290	275	250	225	200	1,66	120/60
VK 250	10"	no	4,3	2523	266	2,25	620**	683	653	620**	588	551**	518	487**	453	423	394	368	3,1	120/60
VK 315	12"	no	4,1	2641	269	2,25	770**	871	825	770**	736	683**	645	569**	515	476	430	388**	2,8	120/60

* The parameters RPM, Watts, Amps are indicated at 0.2 in WG static pressure

**HVI rated

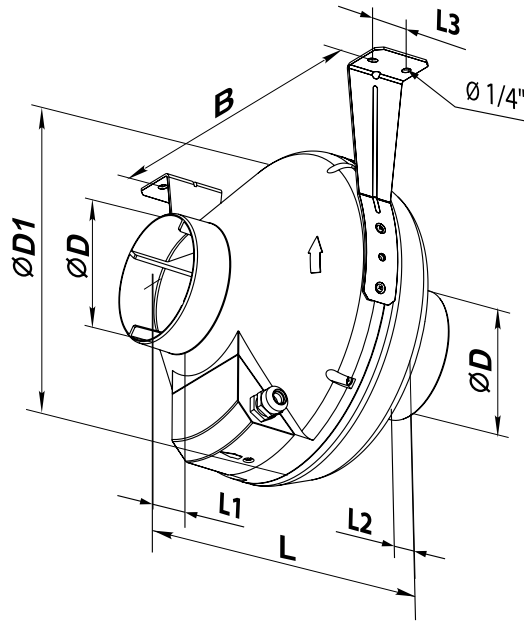

Model	Measurements [in.]							lbs
	ØD	ØD1	B	L	L1	L2	L3	
VK 100	3 15/16"	9 13/16"	10 5/8"	9 1/16"	1 3/16"	1 1/16"	1 3/16"	4.7
VK 125	4 15/16"	9 13/16"	10 5/8"	8 11/16"	1 3/16"	1 1/16"	1 3/16"	4.9
VK 150 E	5 7/8"	11 13/16"	12 3/16"	11 1/4"	1 3/16"	1 3/16"	1 3/16"	5.7
VK 150	5 7/8"	11 13/16"	12 3/16"	11 1/4"	1 3/16"	1 3/16"	1 3/16"	5.7
VK 200 E	7 7/8"	13 3/8"	13 15/16"	10 7/8"	1 3/16"	1 3/16"	1 9/16"	8.8
VK 200	7 7/8"	13 3/8"	13 15/16"	10 7/8"	1 3/16"	1 3/16"	1 9/16"	8.8
VK 250	9 13/16"	13 3/8"	13 15/16"	10 7/16"	1 3/16"	1 3/16"	1 9/16"	9.9
VK 315	12 3/8"	15 3/4"	16 5/16"	16 5/16"	1 9/16"	2 3/16"	1 9/16"	11.2

DESIGN AND OPERATING PRINCIPLE

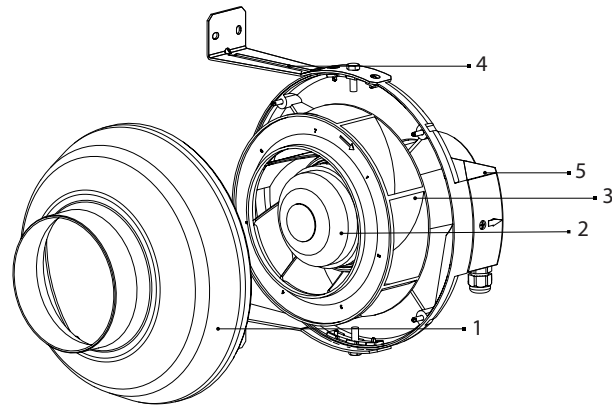

1. Casing
2. Motor
3. Impeller
4. Mounting bracket
5. Terminal box

The fan is equipped with a single-phase motor with an external rotor, equipped with a centrifugal impeller. The fan is rated for continuous operation.

Electronics operation algorithm

The **VK U/U1/U2** fan is equipped with an electronic module TSC (speed controller with an electronic thermostat) for automatic speed control (air flow) depending on the air temperature.

The terminal compartment incorporates 2 control knobs:

- presetting speed
- setting electric thermostat threshold value

The fan is equipped with two indicators:

- temperature sensor indicator (hereinafter referred to as TSI) - yellow colour
- motor control indicator (hereinafter referred to as MCI) - green/yellow colour

When the fan turns on, the TSI indicates the unit operation algorithm:

- one pulse - U
- two pulses - U1
- three pulses - U2

The MCI lights up in green when the motor rotates and in red when it stops (or rotates very slowly). To set the thermostat threshold, rotate the thermostat control knob clockwise to increase or counter-clockwise to decrease the temperature set point. To set the fan speed (air flow), rotate the speed control knob in the same way.

VK U: In this case, fan speed switching operations are rare.

The TSI lights up and the fan switches to the maximum speed as the room air temperature exceeds the set point.

As the air temperature drops 35,6 °F below the set point or if the initial temperature is below the set point, the TSI goes out and the fan operates with the set speed.

VK U1: The speed switching operations are more frequent as compared to the temperature-based functioning logic (U), but one speed interval continues at least 5 minutes.

The TSI lights up and the fan switches to the maximum speed as the room air temperature exceeds the set point.

As the air temperature drops down below the set point, the TSI starts blinking, the timer starts a 5-minute countdown and then the fan switches to the set lower speed and the TSI goes out.

VK U2: The fan starts only at a certain air temperature.

The TSI lights up and the fan switches to the set speed as the room air temperature exceeds the set point.

As the air temperature drops 35,6 °F below the set point or if the initial temperature is below the set point, the TSI goes out and the fan turns off.

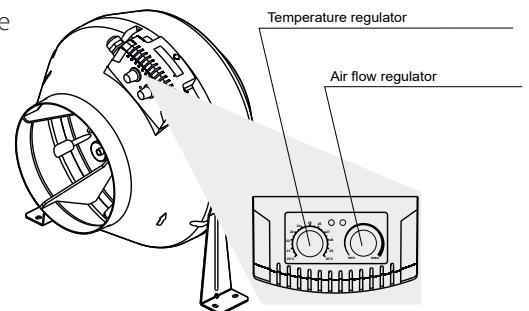

Temperature sensor failure

Alarm code	Alarm description
Two short pulses	Short circuit of the temperature sensor
One pulse	Breakdown of the temperature sensor

The motor shuts down

MOUNTING AND SET-UP



READ THE USER'S MANUAL BEFORE INSTALLING THE UNIT

The fan is suitable both for horizontal or vertical mounting on the floor, on the wall or on the ceiling.

Air motion in the system must be in compliance with the direction of the arrow on the fan casing.

Install a hood on the intake spigot side in case of vertical fan installation.

When installing the fan horizontally, provide a straight air duct section at least 40 in long on the intake spigot side.

The fans are designed for duct mounting in any point of the ventilation system with the casing mounted at any angle.

In case of vertical mounting a protective outer hood must be installed on the top.

Fixation to the floor wall or ceiling is performed with the supplied mounting brackets.

To attain the best performance of the ventilation system and to minimize turbulence-induced air pressure losses while mounting connect a straight air duct section on both sides of the unit.

Minimum straight air duct length:

- equal to 1 air duct diameter on intake side;
- equal to 3 air duct diameters on outlet side.

Typical Fan installation

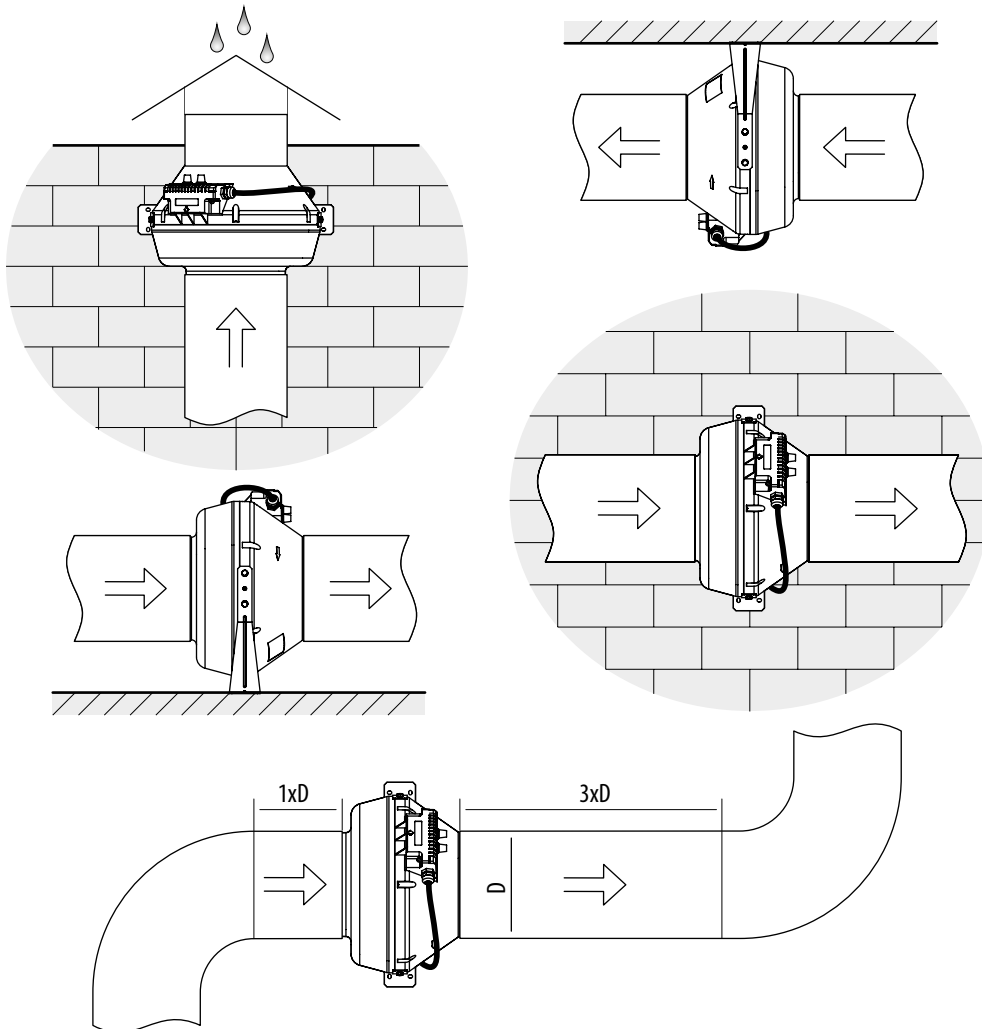

Mounting sequence

1. Attach mounting brackets.
2. Mark fastening holes
3. Drill fastening holes
4. Fix the fan.
5. Connect air ducts.

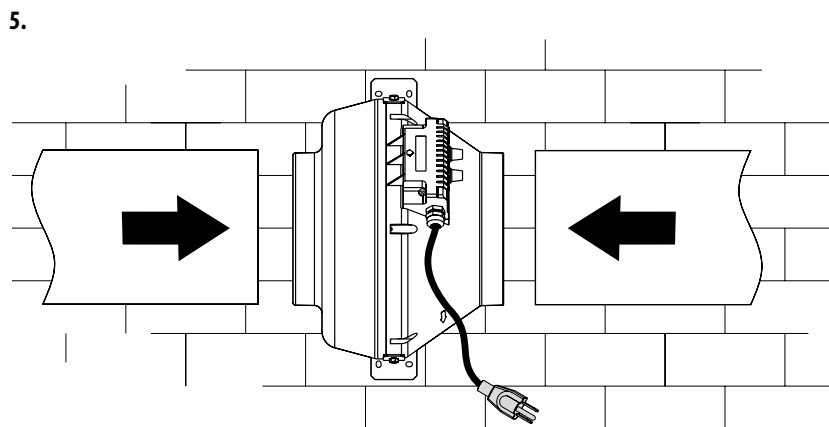
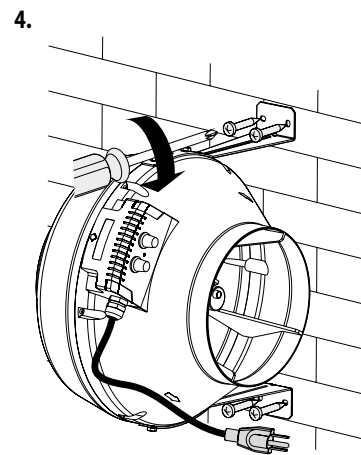
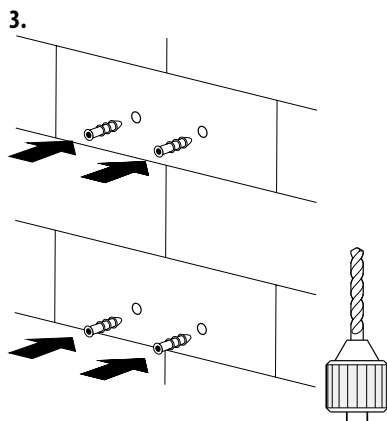
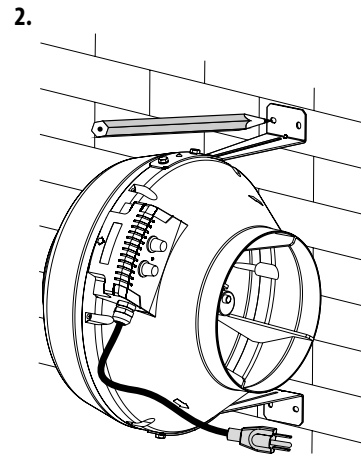
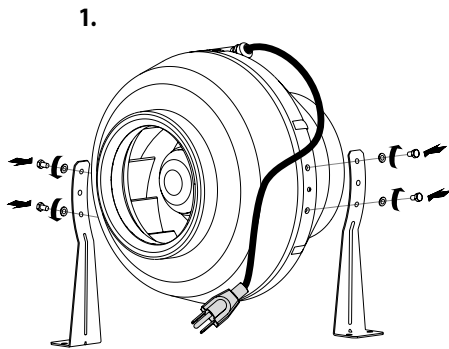

CONNECTION TO POWER MAINS

⚠️ POWER OFF THE POWER SUPPLY PRIOR TO ANY OPERATIONS WITH THE UNIT. THE UNIT MUST BE CONNECTED TO POWER SUPPLY BY A QUALIFIED ELECTRICIAN. THE RATED ELECTRICAL PARAMETERS OF THE UNIT ARE GIVEN ON THE MANUFACTURER'S LABEL.

⚠️ ANY TAMPERING WITH THE INTERNAL CONNECTIONS IS PROHIBITED AND WILL VOID THE WARRANTY.

The unit is rated for connection to power mains with the parameters specified in the "Technical specifications" section, according to the wiring diagram.

The external power input must be equipped with an automatic circuit breaker QF built into the stationary wiring to open the circuit in the event of overload or short-circuit.

The position of the external automatic circuit breaker must ensure free access for quick power-off of the unit.

The trip current of the automatic circuit breaker must exceed the maximum current consumption of the unit (refer to the "Technical data" section or to the unit label).

The recommended trip current of the circuit breaker is the next current in the standard trip current row following the maximum current of the connected unit.

The circuit breaker is not included in the delivery set and can be ordered separately.

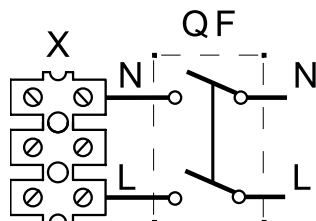
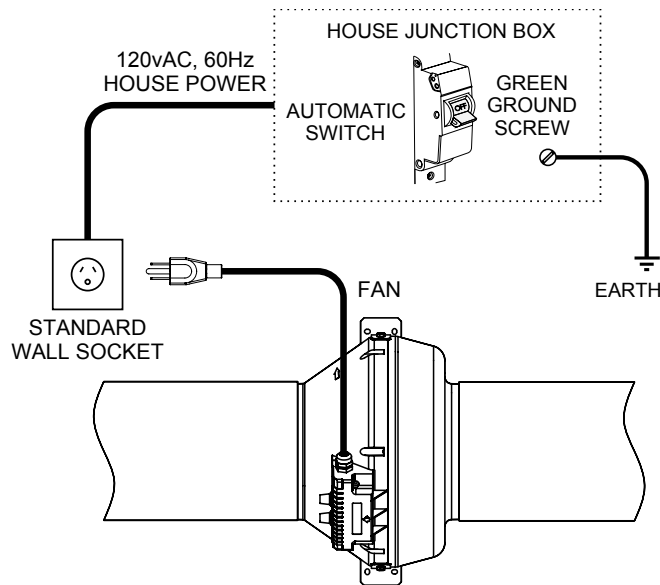

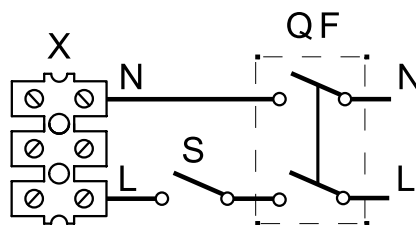
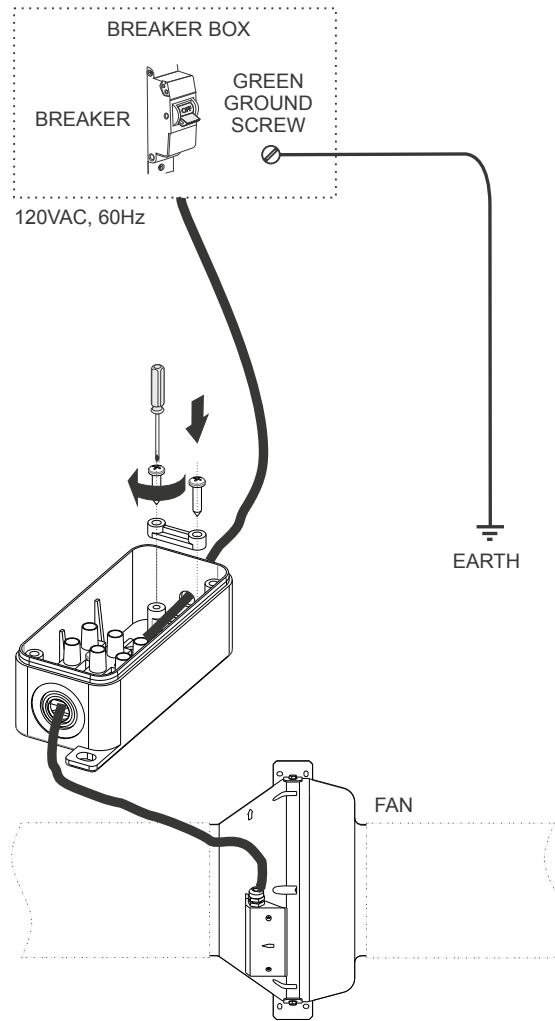

Designation:

L – line; **N** – neutral; **QF** – automatic circuit breaker; **S** – external switch; **X** – input terminal block

WARNING! The fan is equipped with a thermal switch without self-resetting function. To avoid a random restart of the thermal switch, the unit must not be powered through an external switching device, such as a timer, or connected to power mains usually turned on/off by public services.

TECHNICAL MAINTENANCE



DISCONNECT THE UNIT FROM POWER SUPPLY BEFORE ANY MAINTENANCE OPERATIONS!

MAKE SURE THE UNIT IS DISCONNECTED FROM POWER MAINS BEFORE REMOVING THE PROTECTION.

Clean the product surfaces regularly (once in 6 months) from dust and dirt. To clean the fan, remove the self-tapping screws and remove the fan cover. To clean the fan, use a soft cloth or a brush wetted in a mild detergent solution. Do not allow water or liquid come into contact with electric components. Wipe the unit surfaces dry after cleaning. Install the cover back in place and screw the self-tapping screws.

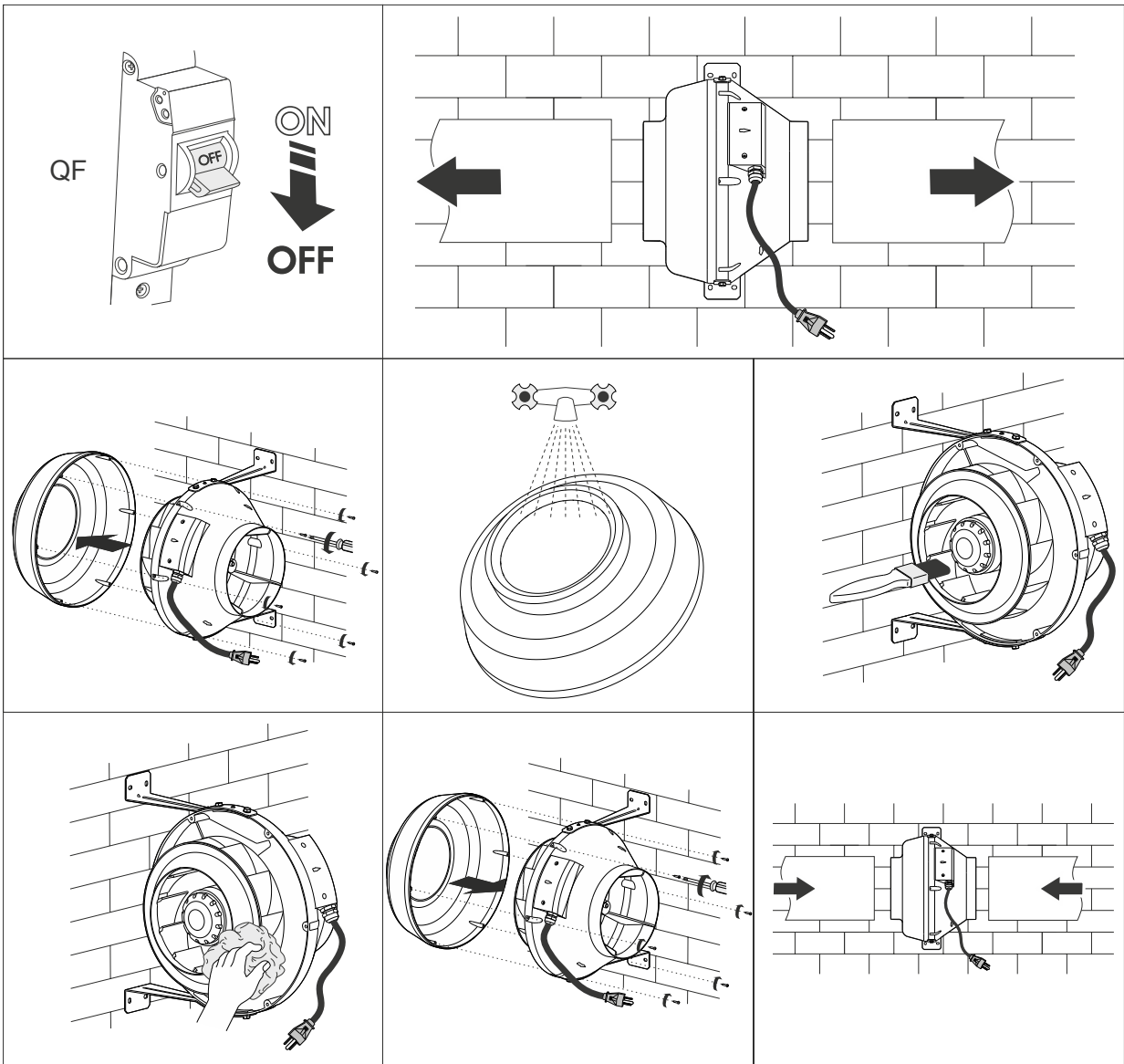

STORAGE AND TRANSPORTATION REGULATIONS

- Store the unit in the manufacturer's original packaging box in a dry closed ventilated premise with temperature range from +41 °F to +104 °F and relative humidity up to 70 %.
- Storage environment must not contain aggressive vapors and chemical mixtures provoking corrosion, insulation, and sealing deformation.
- Use suitable hoist machinery for handling and storage operations to prevent possible damage to the unit.
- Follow the handling requirements applicable for the particular type of cargo.
- The unit can be carried in the original packaging by any mode of transport provided proper protection against precipitation and mechanical damage. The unit must be transported only in the working position.
- Avoid sharp blows, scratches, or rough handling during loading and unloading.
- Prior to the initial power-up after transportation at low temperatures, allow the unit to warm up at operating temperature for at least 3-4 hours.

MANUFACTURER'S WARRANTY

Production meets standard operating requirements in the USA and Canada.

Vents US warrants to the original purchaser of the unit that it will be free from defects in materials or workmanship for a period of 24 months from the date of original purchase. The Vents US warrants to the original purchaser of the unit that the integrated control unit will be free from defects in materials and workmanship for a period of 24 months from the date of original purchase.

THERE ARE NO OTHER WARRANTIES, EXPRESS OR IMPLIED, INCLUDING, BUT NOT LIMITED TO, IMPLIED WARRANTIES OF MERCHANTABILITY OR FITNESS FOR A PARTICULAR PURPOSE.

During the stated warranty period, Vents US will, at its option, repair or replace, without charge, any product or part which is found to be defective under normal use and service. This warranty does not cover (a) normal maintenance and normal service or (b) any products or parts which have been subject to misuse, negligence, accident, improper maintenance or repair (other than by Vents US), faulty installation or installation contrary to recommended installation instructions. Labor to remove and replace products is not covered. The duration of any implied warranty is limited to the time period specified for the express warranty. Some states do not allow limitations on how long an implied warranty lasts, so the above limitation may not apply to you.

VENTS US OBLIGATION TO REPAIR OR REPLACE, AT VENTS US OPTION, SHALL BE THE PURCHASER'S SOLE AND EXCLUSIVE REMEDY UNDER THIS WARRANTY. VENTS US SHALL NOT BE LIABLE FOR INCIDENTAL, CONSEQUENTIAL OR SPECIAL DAMAGES ARISING OUT OF OR IN CONNECTION WITH PRODUCT USE OR PERFORMANCE.

Some states do not allow the exclusion or limitations of incidental or consequential damages, so the above limitation or exclusion may not apply to you. This warranty gives you specific legal rights, and you may also have other rights which vary from state to state. This warranty supersedes all prior warranties. If proof of sales date is absent, warranty period is calculated from the production date. The unit can be exchanged at the following address:

Vents-US
 400 Murray Road, Cincinnati, OH 45217, USA
 Tel: 1-888-640-0925, 513-583-5786, Fax: 513-268-4597
 E-mail: support@ventsus.com
 www.vents-us.com

Please follow guidelines in this manual for product problem-free operation.



FOLLOWING THE REGULATIONS STIPULATED HEREIN WILL ENSURE A LONG AND TROUBLE-FREE OPERATION OF THE UNIT



USER'S WARRANTY CLAIMS SHALL BE SUBJECT TO REVIEW ONLY UPON PRESENTATION OF THE UNIT, THE PAYMENT DOCUMENT AND THE USER'S MANUAL WITH THE PURCHASE DATE STAMP

CERTIFICATE OF ACCEPTANCE

Unit Type	Centrifugal fan
Model	
Serial Number	
Manufacture Date	
Quality Inspector's Stamp	

SELLER INFORMATION

Seller	
Address	
Phone Number	
E-mail	
Purchase Date	
This is to certify acceptance of the complete unit delivery with the user's manual. The warranty terms are acknowledged and accepted.	
Customer's Signature	

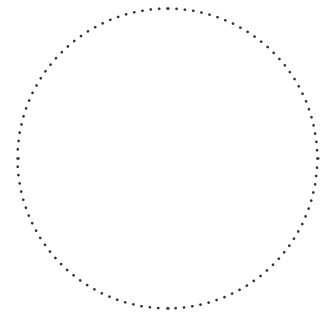

Seller's Stamp

INSTALLATION CERTIFICATE

The _____ unit is installed pursuant to the requirements stated in the present user's manual.	
Company name	
Address	
Phone Number	
Installation Technician's Full Name	
Installation Date:	Signature:
The unit has been installed in accordance with the provisions of all the applicable local and national construction, electrical and technical codes and standards. The unit operates normally as intended by the manufacturer.	
Signature:	

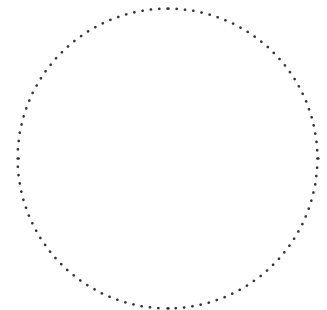

Installation Stamp

WARRANTY CARD

Unit Type	Centrifugal fan
Model	
Serial Number	
Manufacture Date	
Purchase Date	
Warranty Period	
Seller	

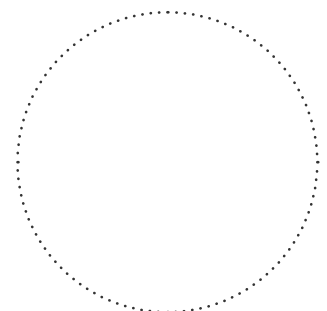

Seller's Stamp

