



CASING

Fans have a housing made of steel with polymer coating.

MOTOR

Motors are supplied with automatic reset thermal protection and are equipped with ball bearings for longer service life (40,000 hrs). Suitable for air stream temperature from -13 °F to 105 °F.

DIMENSIONS

| Model | Measurements [in.] | | | | | | | | Duct dia |
|---------|--------------------|----------|---------|-----------|----------|--------|--------|--------|----------|
| | Ø D | Ø D1 | B | B1 | L | L1 | L2 | L3 | |
| VKM 400 | 15 11/16" | 22 7/16" | 26 1/8" | 24 15/16" | 22 7/16" | 2 3/8" | 2 3/8" | 2 3/4" | 16" |

PERFORMANCE

| Model | Duct Dia. | Energy Star Compliant | Current* [Amp] | Power* [W] | Sones | RPM* | Max. Ps | CFM vs. Static Pressure [Ps] in.W.G. | | | | | | | | | | | Volt/Hz |
|---------|-----------|-----------------------|----------------|------------|-------|------|---------|--------------------------------------|------|------|------|------|------|------|------|------|------|-----|---------|
| | | | | | | | | 0" | 0.1" | 0.2" | 0.3" | 0.4" | 0.5" | 0.6" | 0.7" | 0.8" | 0.9" | 1" | |
| VKM 400 | 16" | No | 3.05 | 673 | 9.8 | 1585 | 2.81 | 2071 | 2050 | 1989 | 1972 | 1913 | 1854 | 1700 | 1589 | 1413 | 1236 | 294 | 220/60 |

* The parameters RPM, Watts, Amps are indicated at 0.2 in WG static pressure.

DESCRIPTION

VENTS VKM inline centrifugal duct fans are designed for residential and commercial ventilation applications. The fan's housing is made of steel with polymer coating. The quiet and efficient backward curved impeller is capable of operating in high pressure systems. In-line configuration simplifies installation. All VKM models are designed for standard diameter round ducting. VENTS VKM inline duct fans can eliminate many ventilation problems. They are designed to boost airflow through long or complex duct runs and provide ideal solutions for residential and commercial applications. VENTS VKM sizes range from 4" to 18" with airflows ranging up to 3716 CFM. The VKM series fans are specifically for simple installation and maintenance free operation.

SUITABLE FOR:

Bathroom exhaust; kitchen ventilation; living area; whole house ventilation; workshops & smoking areas; offices; bars & restaurants; warehouses; duct boosting.

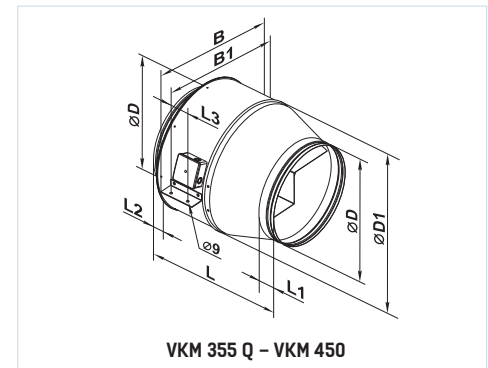

| MODEL | QUANTITY | COMMENTS | PROJECT |
|-------|----------|----------|---------------|
| | | | location: |
| | | | architect: |
| | | | engineer: |
| | | | contractor: |
| | | | submitted by: |

Tel: 888-640-0925
513-583-5786

Sales@vents-us.com
Vents-US.com
400 Murray Rd,
Cincinnati, OH 45217