

USER'S MANUAL

VKM EC (120/60)

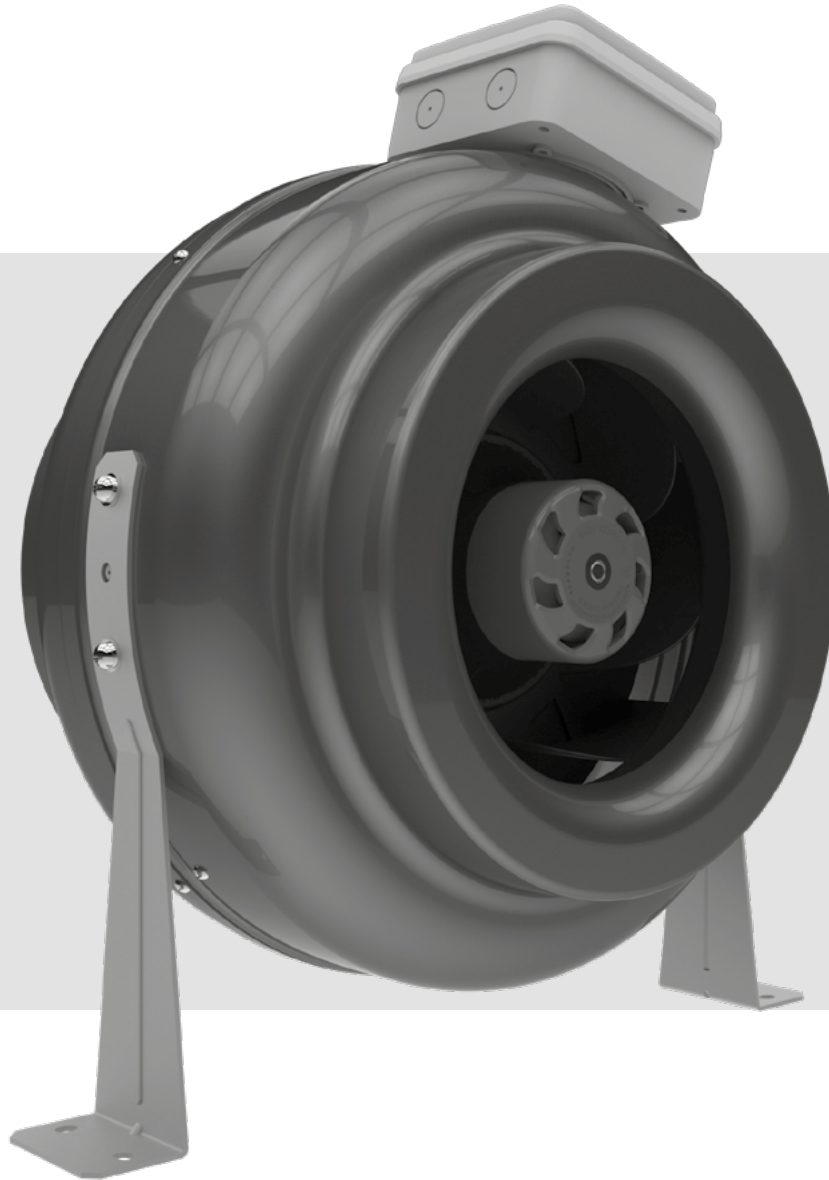

Centrifugal inline fan

CONTENTS

Safety requirements	2
Purpose.....	4
Delivery set.....	4
Designation key.....	4
Technical data.....	5
Installation and set-up	6
Connection to power mains	8
Technical maintenance.....	10
Storage and transportation requirements	11
Manufacturer's warranty	12
Certificate of acceptance	13
Seller information.....	13
Installation certificate	13
Warranty card.....	13

This user's manual is the primary operating document intended for technical, maintenance and operations staff.

The user's manual contains information regarding the field of application, delivery package, operating principle, and design of the VKM EC fan and all its modifications.

Technical and maintenance staff must have proper theoretical knowledge and practical training specific to ventilation systems as well as the necessary skills to carry out the work in accordance with labour safety and construction regulations and standards applicable in the respective territory.

The information provided in the present document is true as at the document preparation.

Due to the continuous product development the company reserves the right to update the technical specifications, design or delivery package of its products.

No part of the present publication may be reproduced, uploaded or saved in reference-providing information systems or translated into other languages in any form whatsoever without the company's prior written consent.

SAFETY REQUIREMENTS

WARNING – TO REDUCE THE RISK OF FIRE, ELECTRIC SHOCK, OR INJURY TO PERSONS, OBSERVE THE FOLLOWING:

- Installation work and electrical wiring must be done by qualified person(s) in accordance with all applicable codes and standards, including fire-rated construction.
- Ducted fans must always be vented to the outdoors.
- When cutting or drilling into wall or ceiling, do not damage electrical wiring and other hidden utilities.
- Use this unit only in the manner intended by the manufacturer. If you have questions, contact the manufacturer.
- Before servicing or cleaning unit, switch power off at service panel and lock the service disconnecting means to prevent power from being switched on accidentally.
- When the service disconnecting means cannot be locked, securely fasten a prominent warning device, such as a tag, to the service panel.

This unit is not intended for use by persons (including children) with reduced physical, sensory or mental capabilities, or lack of experience and knowledge, unless they have been given supervision or instruction concerning use of the unit by a person responsible for their safety. Children should be supervised to ensure that they do not play with the unit.

This appliance can be used by children aged from 8 years and above and persons with reduced physical, sensory or mental capabilities or lack of experience and knowledge if they have been given supervision or instruction concerning use of the appliance in a safe way and understand the hazards involved.

Cleaning and user maintenance shall not be done by children without supervision.

Children shall not play with the appliance.

This appliance incorporates an earth connection for functional purposes.

Connection to the mains must be made through a disconnecting device, which is integrated into the fixed wiring system in accordance with the wiring rules for design of electrical units, and has a contact separation in all poles that allows for full disconnection under overvoltage category III conditions.

If the supply cord is damaged, it must be replaced by the manufacturer, its service agent, or similarly qualified persons in order to avoid a safety hazard.

CAUTION: In order to avoid a safety hazard due to inadvertent resetting of the thermal cut-out, this unit must not be supplied through an external switching device, such as a timer, or connected to a circuit that is regularly switched on and off by the utility.

Ensure that the unit is switched off from the supply mains before removing the guard.

WARNING: If there are any unusual oscillating movements, immediately stop using the unit and contact the manufacturer, its service agent or suitably qualified persons.

The replacement of parts of the safety suspension system device shall be performed by the manufacturer, its service agent or suitably qualified persons.

Precautions must be taken to avoid the back-flow of gases into the room from the open flue of gas or other fuel-burning appliances.

The appliance may adversely affect the safe operation of appliances burning gas or other fuels (including those in other rooms) due to back flow of combustion gases. These gases can potentially result in carbon monoxide poisoning. After installation of the unit the operation of flued gas appliances should be tested by a competent person to ensure that back flow of combustion gases does not occur.

All operations described in this manual must be performed by qualified personnel only, properly trained and qualified to install, make electrical connections and maintain ventilation units.

Do not attempt to install the product, connect it to the mains, or perform maintenance yourself. This is unsafe and impossible without special knowledge.

Disconnect the power supply prior to any operations with the unit.

All user's manual requirements as well as the provisions of all the applicable local and national construction, electrical, and technical norms and standards must be observed when installing and operating the unit.

Disconnect the unit from the power supply prior to any connection, servicing, maintenance, and repair operations.

Connection of the unit to power mains is allowed by a qualified electrician with a work permit for the electric units up to 1000 V after careful reading of the present user's manual.

Check the unit for any visible damage of the impeller, the casing, and the grille before starting installation. The casing internals must be free of any foreign objects that can damage the impeller blades.

While mounting the unit, avoid compression of the casing! Deformation of the casing may result in motor jam and excessive noise.

Misuse of the unit and any unauthorised modifications are not allowed.

Do not expose the unit to adverse atmospheric agents (rain, sun, etc.).

Transported air must not contain any dust or other solid impurities, sticky substances, or fibrous materials.

Do not use the unit in a hazardous or explosive environment containing spirits, gasoline, insecticides, etc.

Do not close or block the intake or extract vents in order to ensure the efficient air flow.

Do not sit on the unit and do not put objects on it.

The information in this user's manual was correct at the time of the document's preparation.

The Company reserves the right to modify the technical characteristics, design, or configuration of its products at any time in order to incorporate the latest technological developments.

Never touch the unit with wet or damp hands.

Never touch the unit when barefoot.

BEFORE INSTALLING ADDITIONAL EXTERNAL DEVICES, READ THE RELEVANT USER MANUALS.



THE PRODUCT MUST BE DISPOSED SEPARATELY AT THE END OF ITS SERVICE LIFE.

DO NOT DISPOSE THE UNIT AS UNSORTED DOMESTIC WASTE.



READ AND SAVE THESE INSTRUCTIONS.

PURPOSE

The product described herein is a centrifugal inline fan VKM EC for ventilation of small and medium domestic premises. The unit is rated for continuous operation.



THE UNIT SHOULD NOT BE OPERATED BY CHILDREN OR PERSONS WITH REDUCED PHYSICAL, MENTAL, OR SENSORY CAPACITIES, OR THOSE WITHOUT THE APPROPRIATE TRAINING.

THE UNIT MUST BE INSTALLED AND CONNECTED ONLY BY PROPERLY QUALIFIED PERSONNEL AFTER THE APPROPRIATE BRIEFING.

THE CHOICE OF UNIT INSTALLATION LOCATION MUST PREVENT UNAUTHORISED ACCESS BY UNATTENDED CHILDREN.



THE UNIT MUST NOT BE OPERATED IN KITCHEN PREMISES.

Transported air must not contain any flammable or explosive mixtures, evaporation of chemicals, sticky substances, fibrous materials, coarse dust, soot and oil particles or environments favourable for the formation of hazardous substances (toxic substances, dust, pathogenic germs).



CAUTION- FOR GENERAL VENTILATING USE ONLY. DO NOT USE TO EXHAUST HAZARDOUS OR EXPLOSIVE MATERIALS AND VAPORS.

DELIVERY SET

NAME	QUANTITY
Fan	1 pc.
Fixing bracket	2 pcs.
User's manual	1 pc.
Packing box	1 pc.

DESIGNATION KEY

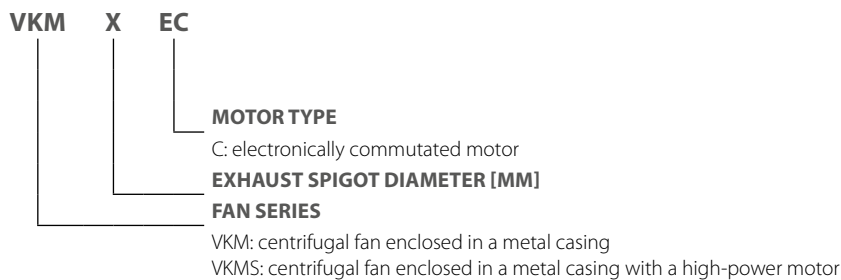

TECHNICAL DATA

The fan is designed for indoor or sheltered application at ambient temperature from -13 °F...+104 °F and relative humidity up to 80 %. The unit is rated as a class I electric appliance. Ingress protection rating against access to hazardous parts and water ingress is IPX4. The unit design is constantly being improved, thus some models may be slightly different from those described in this manual.

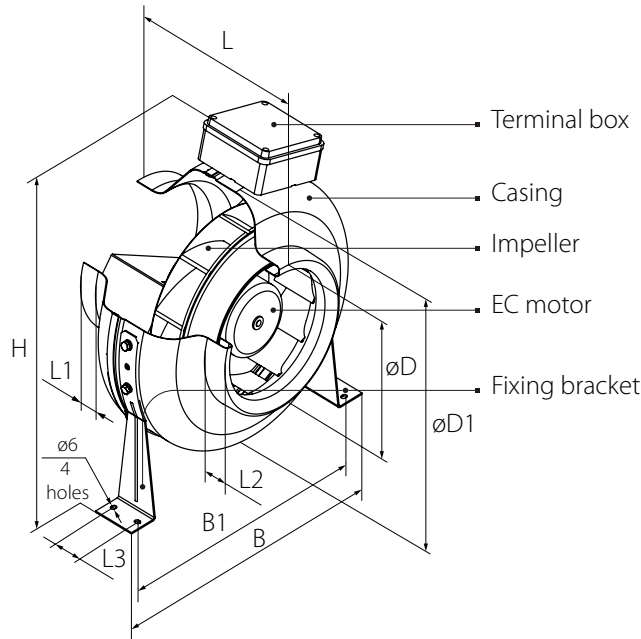

	D	D1	H	B	B1	L	L1	L2	L3
VKM 100 EC	3 ⁶ / ₇	10	13 ² / ₅	12 ¹ / ₅	10 ⁵ / ₈	8	4 ⁴ / ₅	1	1 ¹ / ₆
VKM 125 EC	4 ⁵ / ₆	10	13 ² / ₅	12 ¹ / ₅	10 ⁵ / ₈	8	4 ⁴ / ₅	1	1 ¹ / ₆
VKM 150 EC	5 ⁵ / ₆	12	14 ¹ / ₆	14 ¹ / ₆	12 ³ / ₅	7 ⁷ / ₈	4 ⁴ / ₅	1	1 ¹ / ₆
VKM 200 EC	7 ⁴ / ₅	13 ⁴ / ₇	17 ¹ / ₈	15 ⁵ / ₉	14	9 ² / ₃	1	1 ¹ / ₆	1 ⁴ / ₇
VKM 250 EC	9 ³ / ₄	13 ⁴ / ₇	17 ¹ / ₈	15 ⁵ / ₉	14	9 ⁵ / ₆	1	1 ¹ / ₆	1 ⁴ / ₇
VKM 305 EC	12	16	18 ¹ / ₃	18	16 ¹ / ₃	10 ¹ / ₄	1 ¹ / ₆	1 ¹ / ₆	1 ⁴ / ₇

TECHNICAL DATA

	VKM 100 EC	VKM 125 EC	VKM 150 EC	VKM 200 EC	VKM 250 EC	VKM 305 EC
Power supply voltage, 60 Hz [V]	~120					
Max. power consumption [W]	33	57,1	75,1	99	133,6	173,5
Current consumption [A]	0,51	0,84	1,08	1,45	1,89	2,41
Air capacity [m ³ /h]	257	421	519	916	1133	1360
CFM [ft ³ /min]	151	248	306	539	667	801
Noise level, 3 m [dB(A)]	44	45	47	47	46	48
Transported air temperature [°F]	-13...+104					

INSTALLATION AND SET-UP



READ THE USER'S MANUAL BEFORE INSTALLING THE UNIT

The air motion in the system must be as shown with the pointer of the fan casing.

In case of the vertical installation the intake spigot must be protected with a ventilation hood.

To attain the best performance of the fan and to minimise turbulence-induced air pressure losses while mounting connect straight air duct sections to the fan spigots.

Minimum straight air duct length:

- equal to 1 air duct diameter on intake side
- equal to 3 air duct diameters on outlet side

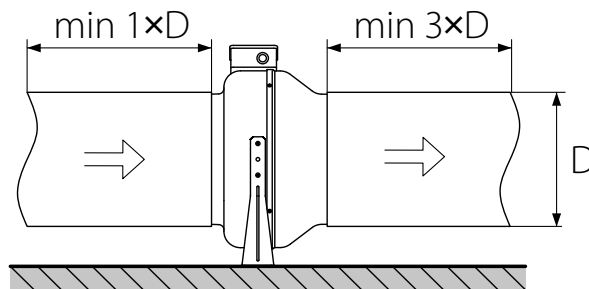

If the air ducts are too short or not connected at any spigot, protect the fan inner parts from ingress of foreign objects by installing a protecting grille or other protecting device with mesh width not more than 1/2 inch to prevent uncontrollable access to the fans.

While installing the fan ensure convenient access for subsequent maintenance and repair.

The unit must be mounted on a an even wall.

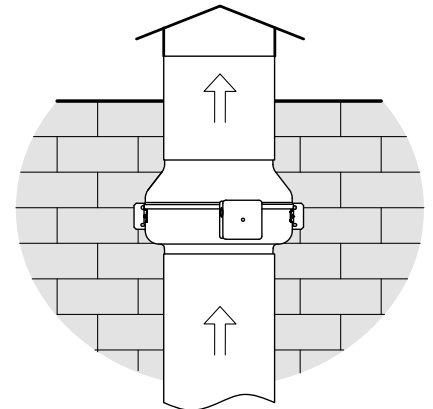
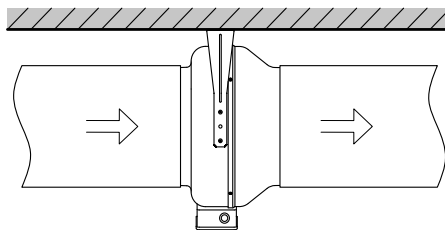
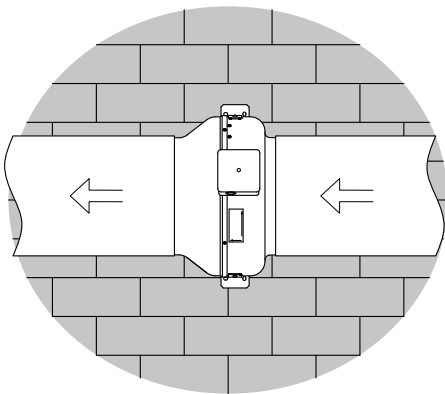

INSTALLATION STEPS

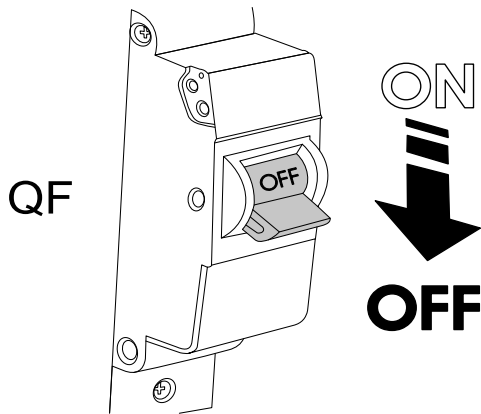

Disconnect the fan from power supply

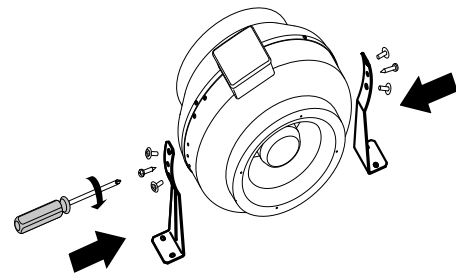

Install the fixing brackets

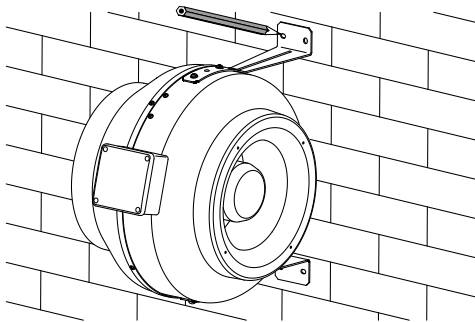

Lean the fan against the installation place and mark the fastening holes

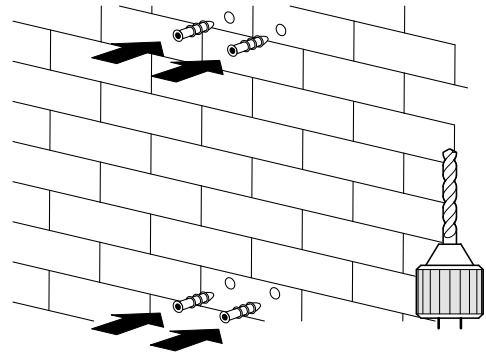

Drill the holes and insert the expansion anchors

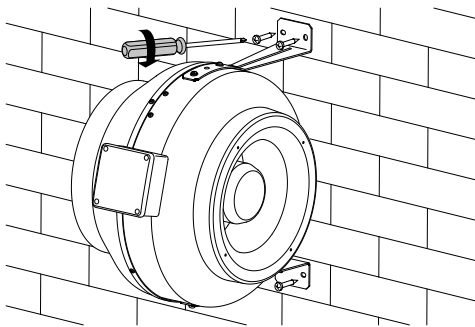

Fix the fan

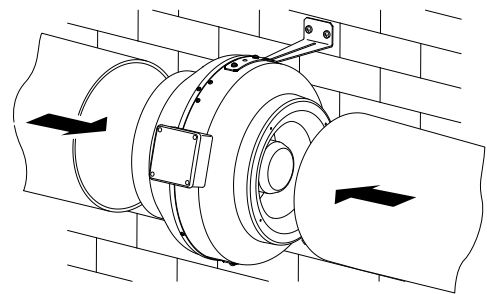

Connect air ducts

CONNECTION TO POWER MAINS



DISCONNECT THE UNIT FROM POWER MAINS PRIOR TO ANY OPERATIONS. THE UNIT MUST BE CONNECTED TO POWER SUPPLY BY A QUALIFIED ELECTRICIAN. THE RATED ELECTRICAL PARAMETERS OF THE UNIT ARE GIVEN ON THE MANUFACTURER'S LABEL.



ANY TAMPERING WITH THE INTERNAL CONNECTIONS IS PROHIBITED AND WILL VOID THE WARRANTY.



WARNING - TO REDUCE THE RISK OF FIRE OR ELECTRIC SHOCK, DO NOT USE THIS FAN WITH ANY SOLID-STATE SPEED CONTROL DEVICE.

The unit is rated for connection to single-phase ac 120V/ 60 Hz power mains. For electric installations use insulated durable heat-resistant conductors (cables, wires) with the minimum wire cross section AWG19. The conductor cross section value must be selected on the wire type, maximum permissible heating temperature, insulation, length and installation method.

Connect the fan to power mains via an external automatic circuit breaker installed at the power input and integrated in the house cabling to open the circuit in case of short circuit or overload.

The circuit breaker location must provide quick access for emergency shutdown of the fan.

Connection of the fan to power supply is performed via the terminal block located in the terminal box attached to the fan casing in compliance with the wiring diagram and designation of terminals.

EXTERNAL WIRING

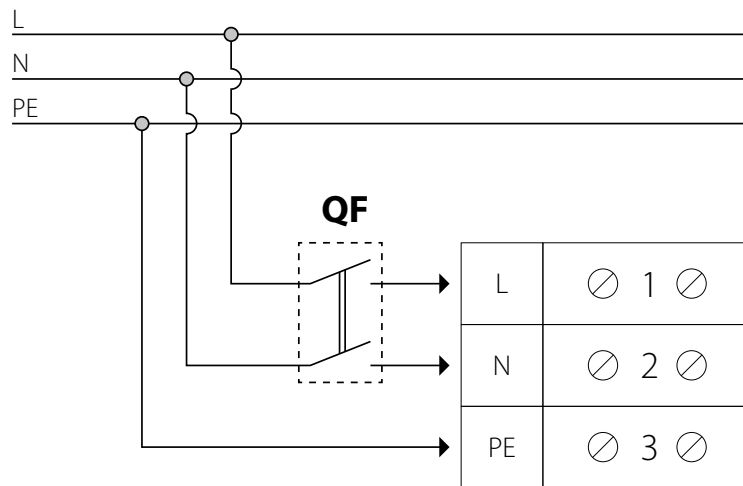

The recommended fan speed controller is Vents R-1/010.

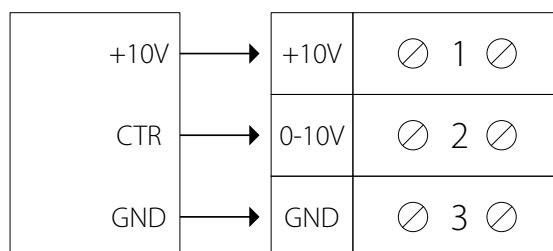

For smooth air flow control it is recommended to use the speed controller R-1/010.

The speed controller is not included in the delivery set and is available as a specially ordered accessory.

ACCESS TO THE TERMINAL BOX

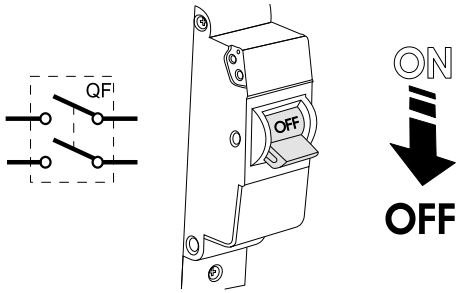

Disconnect the fan from power supply

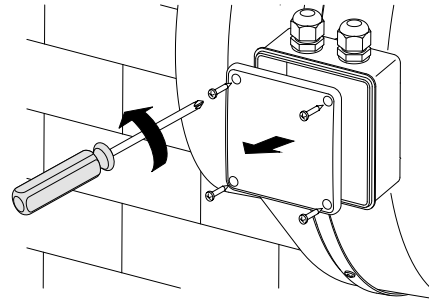

Unscrew the 4 screws that fix the terminal box lid

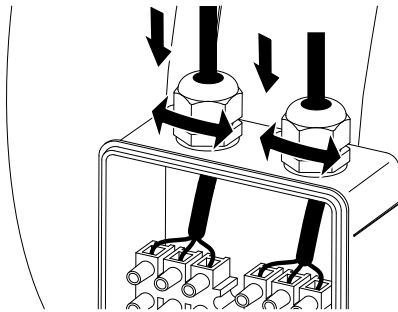

Route the cables through the cable gland and complete electric connection

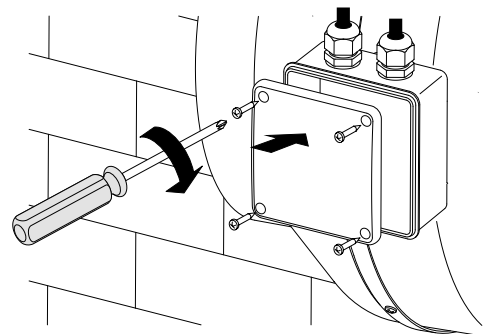

Install the terminal box cover again

MAINTENANCE



DISCONNECT THE UNIT FROM POWER SUPPLY BEFORE ANY MAINTENANCE OPERATIONS!



WARNING - UNPLUG OR DISCONNECT THE APPLIANCE FROM THE POWER SUPPLY BEFORE SERVICING.

Technical maintenance means regular cleaning of the unit surfaces of dust. Use a soft brush or compressed air to remove dust. Clean the impeller blades at least every 6 months. Installation of an air filter prolongs the interval between the cleaning, to perform the cleaning first remove the screws and the fan cover. Wipe the impeller blades with a cloth wetted in a mild detergent solution. Avoid water dripping on the electric motor! After cleaning of the impeller install the cover and tighten the screws.

TECHNICAL MAINTENANCE STEPS

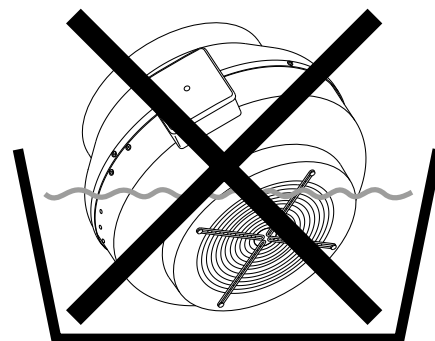
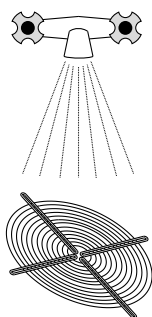
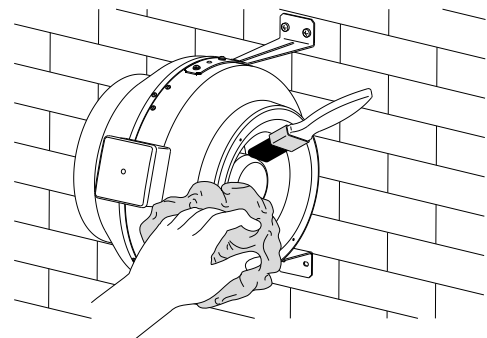
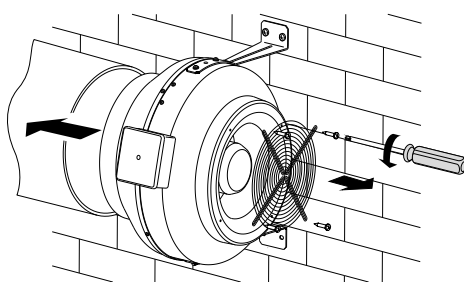
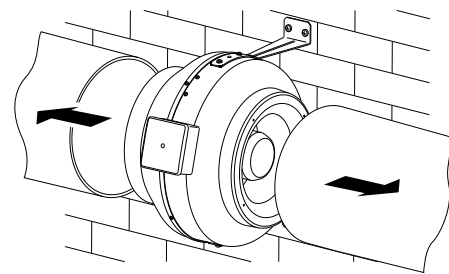
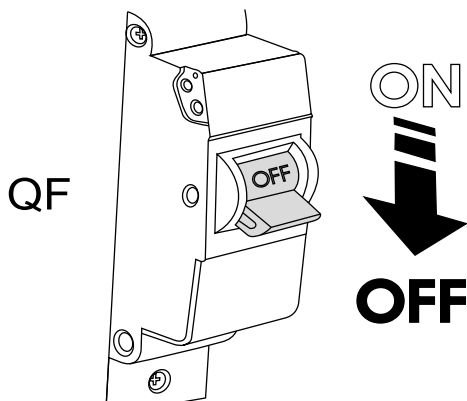

STORAGE AND TRANSPORTATION REGULATIONS

- Store the unit in the manufacturer's original packaging box in a dry closed ventilated premise with temperature range from +41 °F to +104 °F and relative humidity up to 70 %.
- Storage environment must not contain aggressive vapours and chemical mixtures provoking corrosion, insulation, and sealing deformation.
- Use suitable hoist machinery for handling and storage operations to prevent possible damage to the unit.
- Follow the handling requirements applicable for the particular type of cargo.
- The unit can be carried in the original packaging by any mode of transport provided proper protection against precipitation and mechanical damage. The unit must be transported only in the working position.
- Avoid sharp blows, scratches, or rough handling during loading and unloading.
- Prior to the initial power-up after transportation at low temperatures allow the unit to warm up at room temperature for at least 3-4 hours.

MANUFACTURER'S WARRANTY

Production meets standard operating requirements in the USA and Canada.

VENTS warrants to the original purchaser of the unit that it will be free from defects in materials or workmanship for a period of 24 months from the date of original purchase. The VENTS warrants to the original purchaser of the unit that the integrated control unit will be free from defects in materials and workmanship for a period of 24 months from the date of original purchase.

THERE ARE NO OTHER WARRANTIES, EXPRESS OR IMPLIED, INCLUDING, BUT NOT LIMITED TO, IMPLIED WARRANTIES OF MERCHANTABILITY OR FITNESS FOR A PARTICULAR PURPOSE.

During the stated warranty period, VENTS will, at its option, repair or replace, without charge, any product or part which is found to be defective under normal use and service. This warranty does not cover (a) normal maintenance and normal service or (b) any products or parts which have been subject to misuse, negligence, accident, improper maintenance or repair (other than by VENTS), faulty installation or negligence, accident, improper maintenance or repair (other than by VENTS), faulty installation or installation contrary to recommended installation instructions. Labor to remove and replace products is not covered. The duration of any implied warranty is limited to the time period specified for the express warranty. Some states do not allow limitations on how long an implied warranty lasts, so the above limitation may not apply to you.

VENTS US OBLIGATION TO REPAIR OR REPLACE, AT VENTS US OPTION, SHALL BE THE PURCHASER'S SOLE AND EXCLUSIVE REMEDY UNDER THIS WARRANTY. VENTS US SHALL NOT BE LIABLE FOR INCIDENTAL, CONSEQUENTIAL OR SPECIAL DAMAGES ARISING OUT OF OR IN CONNECTION WITH PRODUCT USE OR PERFORMANCE.

Some states do not allow the exclusion or limitations of incidental or consequential damages, so the above limitation or exclusion may not apply to you. This warranty gives you specific legal rights, and you may also have other rights which vary from state to state. This warranty supersedes all prior warranties. If proof of sales date is absent, warranty period is calculated from the production date. The unit can be exchanged at the following address:

Bodor Vents, LLC DBA: VENTS
11013 Kenwood Road Cincinnati, Ohio 45242
Phone: (513)348-3853
e-mail: sales@ventsus.com

Please follow guidelines in this manual for product problem-free operation.



FOLLOWING THE REGULATIONS STIPULATED HEREIN WILL ENSURE A LONG AND TROUBLE-FREE OPERATION OF THE UNIT



USER'S WARRANTY CLAIMS SHALL BE SUBJECT TO REVIEW ONLY UPON PRESENTATION OF THE UNIT, THE PAYMENT DOCUMENT AND THE USER'S MANUAL WITH THE PURCHASE DATE STAMP

CERTIFICATE OF ACCEPTANCE

Unit Type	Centrifugal inline fan
Model	VKM _____ EC
Serial Number	
Manufacture Date	
Quality Inspector's Stamp	

The product is in compliance with EU norms and standards on low voltage guidelines and electromagnetic compatibility. We hereby declare that the product complies with the protection requirements of Electromagnetic Council Directive 2014/30/EU, Low Voltage Directive 2014/35/EU and CE-marking Directive 93/68/EEC on the approximation of the laws of the Member States relating to electromagnetic compatibility.

SELLER INFORMATION

Seller	
Address	
Phone Number	
E-mail	
Purchase Date	
This is to certify acceptance of the complete unit delivery with the user's manual. The warranty terms are acknowledged and accepted.	
Customer's Signature	

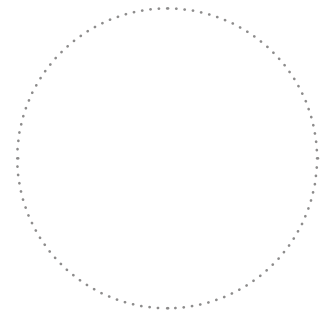

Seller's Stamp

INSTALLATION CERTIFICATE

The centrifugal inline fan VKM _____ EC has been connected to power mains pursuant to the requirements stated in the present user's manual.	
Seller	
Address	
Phone Number	
Installation Technician's Full Name	
Installation Date:	Signature:
The unit has been installed in accordance with the provisions of all applicable local and national construction, electrical, and technical codes and standards. The unit operates normally as intended by the manufacturer.	
Signature:	

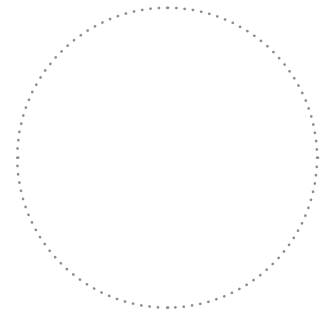

Installation Company Stamp

WARRANTY CARD

Unit Type	Centrifugal inline fan
Model	VKM _____ EC
Serial Number	
Manufacture Date	
Purchase Date	
Warranty Period	
Seller	

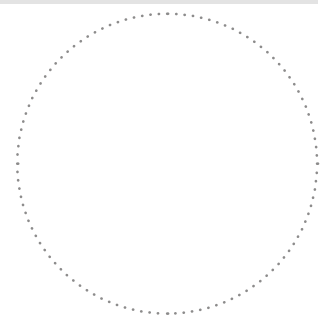

Seller's Stamp

