



DESCRIPTION

The air-handling units are the fully featured ventilation units with heat recovery for air filtration, fresh air supply and stale air extract. During operation the extract air heat is transferred to the supply air stream by the highly efficient plate heat exchanger.

The units are designed for energy efficient ventilation of cottages and flats and are compatible with round air ducts $\varnothing 6 \frac{1}{4}$ ".

CASING

Made of high-quality polymer coated steel, internally filled with $1 \frac{1}{4}$ " (depending on the unit model) mineral wool layer for heat and sound insulation

FANS

The units are equipped with high-efficient EC motors with an external rotor and a centrifugal impeller with backward curved blades. These state-of-the-art motors are the most advanced solution in energy efficiency today.

EC motors are characterised with high performance and optimum control across the entire speed range. In addition to that, the efficiency of the electronically commutated motor reaches very impressive levels of up to 90 %.

AUTOMATION

The **VUE VB EC A21** are equipped with a built-in automation system. The remote control panel is not included in the delivery set (available separately). To control the unit via Wi-Fi, download the VENTS AHU mobile app.

FILTER

Supply and exhaust air is purified in panel filters with filtering class **MERV 8** and **MERV 13**, respectively.

HEAT EXCHANGER

The **VUE VB EC** units are equipped with a counterflow enthalpy heat exchanger. In the cold season the extract air heat and moisture are transferred to the supply air stream through the enthalpy heat exchanger reducing the heat losses from ventilation. The ambient air heat and moisture are transferred to the exhaust air stream through the enthalpy heat exchanger in the warm season.

This allows for a considerable reduction of the supply air temperature and humidity which, in turn, reduces the air conditioning load.

BYPASS

The **VUE VB EC** units are equipped with a bypass for summer ventilation (air cooling by the cool air from outside).

TECHNICAL DATA

A-weighted sound power level	Gen. dBA	Octave frequency band [Hz]									LpA, 3 m dBA	LpA, 1 m dBA
		63	125	250	500	1000	2000	4000	8000			
LwA to supply air inlet	dBA	56	50	46	53	45	39	34	36	32		
LwA to supply air outlet	dBA	64	56	52	63	52	39	38	43	35		
LwA to exhaust air inlet	dBA	56	52	46	53	45	38	34	36	31		
LwA to exhaust air outlet	dBA	64	58	53	62	51	40	38	42	33		
LwA to environment	dBA	49	45	40	44	38	33	29	27	22	28	38

Parameters	VUE 350 VB EC
Unit voltage [V/50 (60) Hz]	1-230
Maximum power [W]	178
Maximum current [A]	2.8
Maximum air flow [CFM]	266
RPM [min ⁻¹]	3200
Sound pressure level at 3 m distance [dBA]	28
Transported air temperature [°F]	from -13 up to +104
Casing material	Painted steel
Insulation	1 3/4" mineral wool
Extract filter	MERV 8
Supply filter	MERV 13 (optionally MERV 8)
Connected air duct diameter [in]	Ø 6 1/4"
Weight [lb]	141.1
Heat recovery efficiency [%]	from 73 up to 91
Heat exchanger type	counter-flow
Heat exchanger material	enthalpy

Total power. Total sound pressure level.

Point	Total power of the unit [W]	Sound pressure level at 10 ft (3ft) [dBA]
1	177	28 (38)
2	175	27 (37)
3	170	27 (37)
4	71	23 (33)
5	71	22 (32)
6	69	22 (32)
7	21	15 (25)
8	21	14 (24)
9	21	14 (24)

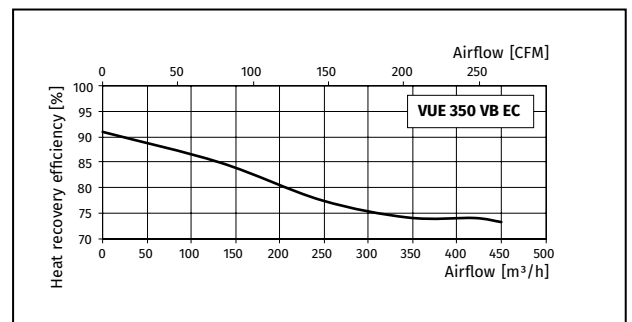
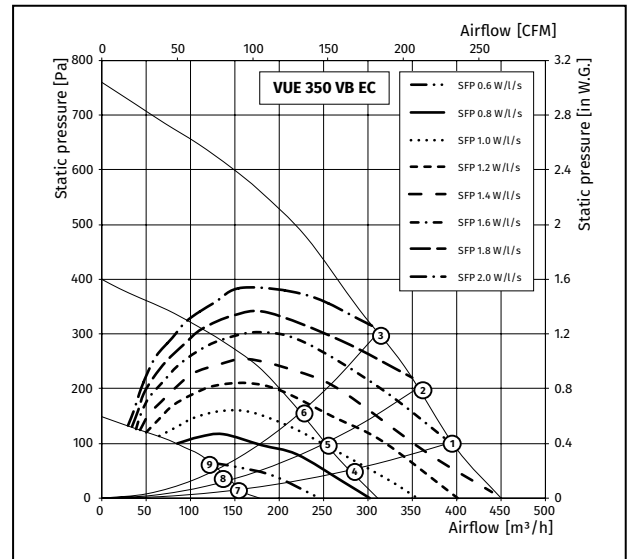

TECHNICAL DATA

VUE 350 VB EC			
Outlet spigot configuration	Air flow [l/s]	Specific power input [W/l/s]	Heat exchange efficiency [%]
Kitchen + 1 additional room with high level of humidity	21	0.71	88
Kitchen + 2 additional rooms with high levels of humidity	29	0.64	88
Kitchen + 3 additional rooms with high levels of humidity	37	0.68	87
Kitchen + 4 additional rooms with high levels of humidity	45	0.76	86
Kitchen + 5 additional rooms with high levels of humidity	53	0.86	86
Kitchen + 6 additional rooms with high levels of humidity	61	1.07	85
Kitchen + 7 additional rooms with high levels of humidity	69	1.26	85

DIMENSIONS

Model	D	B	H	L
VUE 350 VB EC	6 1 ⁹ / ₆₄ "	22 6 ¹ / ₆₄ "	26 3 ⁷ / ₆₄ "	28 4 ⁷ / ₆₄ "

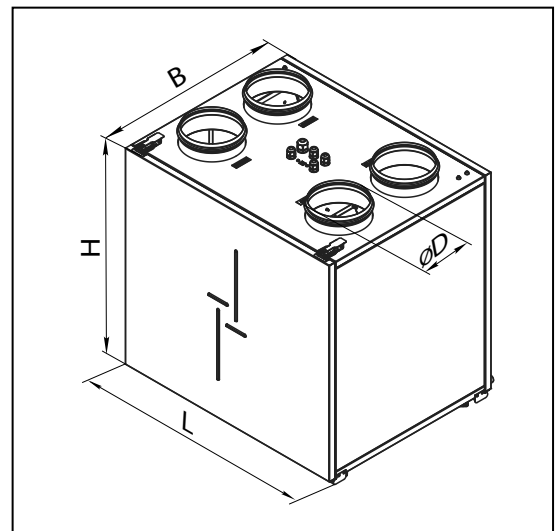

Calculation of air temperature downstream of the heat exchanger:

$$t = t_{\text{outd}} + k_{\text{hr}} \times (t_{\text{extr}} - t_{\text{outd}}) / 100,$$

where

t_{outd} – outdoor air temperature [°F],
 t_{extr} – exhaust air temperature [°F],
 k_{hr} – heat recovery core efficiency (according to the diagram) [%]

MODEL	QUANTITY	COMMENTS	PROJECT
			location:
			architect:
			engineer:
			contractor:
			submitted by:

Tel: 1-888-640-0925
513-583-5786

Sales@vents-us.com
Vents-US.com
400 Murray Road,
Cincinnati, Ohio 45217

