

USER'S MANUAL

VUT 160 V EC
VUE 160 V EC
VUT 160 V1 EC
VUE 160 V1 EC
VUT 160 VB EC
VUE 160 VB EC
VUT 160 V1B EC
VUE 160 V1B EC

VUT 350 V1B EC
VUE 350 V1B EC
VUT 350 VB EC
VUE 350 VB EC
VUT 550 VB EC
VUE 550 VB EC



Air handling unit

CONTENTS

Safety requirements.....	2
Purpose.....	5
Delivery set.....	6
Designation key.....	6
Technical data.....	6
Design and operating principle.....	9
Installation and set-up.....	11
Connection to power mains.....	14
Technical maintenance.....	18
Possible reasons and troubleshooting.....	19
Storage and transportation regulations.....	19
Manufacturer's warranty.....	20
Certificate of acceptance.....	21
Seller information.....	21
Installation certificate.....	21
Warranty card.....	21

This user's manual is a main operating document intended for technical, maintenance, and operating staff.

The manual contains information about purpose, technical details, operating principle, design, and installation of the VUT/VUE 160/350/550 V(1)(B) EC unit and all its modifications.

Technical and maintenance staff must have theoretical and practical training in the field of ventilation systems and should be able to work in accordance with workplace safety rules as well as construction norms and standards applicable in the territory of the country.

SAFETY REQUIREMENTS

This unit is not intended for use by persons (including children) with reduced physical, sensory or mental capabilities, or lack of experience and knowledge, unless they have been given supervision or instruction concerning use of the unit by a person responsible for their safety. Children should be supervised to ensure that they do not play with the unit.

This appliance can be used by children aged from 8 years and above and persons with reduced physical, sensory or mental capabilities or lack of experience and knowledge if they have been given supervision or instruction concerning use of the appliance in a safe way and understand the hazards involved.

Cleaning and user maintenance shall not be made by children without supervision. Children shall not play with the appliance.

Ensure that the unit is switched off from the supply mains before removing the guard.

If the supply cord is damaged, it must be replaced by the manufacturer, its service agent, or similarly qualified persons in order to avoid a safety hazard.

Precautions must be taken to avoid the back-flow of gases into the room from the open flue of gas or other fuel-burning appliances.

The appliance may adversely affect the safe operation of appliances burning gas or other fuels (including those in other rooms) due to back flow of combustion gases. These gases can potentially result in carbon monoxide poisoning. After installation of the unit the operation of flued gas appliances should be tested by a competent person to ensure that back flow of combustion gases does not occur.

All operations described in this manual must be performed by qualified personnel only, properly trained and qualified to install, make electrical connections and maintain ventilation units.

Do not attempt to install the product, connect it to the mains, or perform maintenance yourself. This is unsafe and impossible without special knowledge.

Disconnect the power supply prior to any operations with the unit.

All user's manual requirements as well as the provisions of all the applicable local and national construction, electrical, and technical norms and standards must be observed when installing and operating the unit.

Disconnect the unit from the power supply prior to any connection, servicing, maintenance, and repair operations.

Connection of the unit to power mains is allowed by a qualified electrician with a work permit for the electric units up to 1000 V after careful reading of the present user's manual.

Check the unit for any visible damage of the impeller, the casing, and the grille before starting installation. The casing internals must be free of any foreign objects that can damage the impeller blades.

While mounting the unit, avoid compression of the casing! Deformation of the casing may result in motor jam and excessive noise.

Misuse of the unit and any unauthorised modifications are not allowed.

Do not expose the unit to adverse atmospheric agents (rain, sun, etc.).

Transported air must not contain any dust or other solid impurities, sticky substances, or fibrous materials.

Do not use the unit in a hazardous or explosive environment containing spirits, gasoline, insecticides, etc.

Do not close or block the intake or extract vents in order to ensure the efficient air flow.

Do not sit on the unit and do not put objects on it.

The information in this user's manual was correct at the time of the document's preparation.

The Company reserves the right to modify the technical characteristics, design, or configuration of its products at any time in order to incorporate the latest technological developments.

Never touch the unit with wet or damp hands.

Never touch the unit when barefoot.

BEFORE INSTALLING ADDITIONAL EXTERNAL DEVICES, READ THE RELEVANT USER MANUALS.



**THE PRODUCT MUST BE DISPOSED SEPARATELY AT
THE END OF ITS SERVICE LIFE.
DO NOT DISPOSE THE UNIT AS UNSORTED
DOMESTIC WASTE**



USE THIS UNIT ONLY IN THE MANNER INTENDED BY THE MANUFACTURER. IF YOU HAVE QUESTIONS, CONTACT THE MANUFACTURER.



**THE UNIT SHOULD NOT BE OPERATED BY CHILDREN OR PERSONS WITH REDUCED PHYSICAL, MENTAL, OR SENSORY CAPACITIES, OR THOSE WITHOUT THE APPROPRIATE TRAINING.
THE CHOICE OF UNIT INSTALLATION LOCATION MUST PREVENT UNAUTHORIZED ACCESS BY UNATTENDED CHILDREN.**



**READ THE USER'S MANUAL BEFORE INSTALLING THE UNIT.
INSTALLATION WORK AND ELECTRICAL WIRING MUST BE DONE BY QUALIFIED PERSON(S).
WHEN CUTTING OR DRILLING INTO WALL OR CEILING, DO NOT DAMAGE ELECTRICAL WIRING AND OTHER HIDDEN UTILITIES.
DO NOT MOUNT ROOM-TO-ROOM FAN IN A FIRE-RATED WALL.**



**POWER OFF THE POWER SUPPLY PRIOR TO ANY OPERATIONS WITH THE UNIT.
THE UNIT MUST BE CONNECTED TO POWER SUPPLY BY A QUALIFIED ELECTRICIAN.
THE RATED ELECTRICAL PARAMETERS OF THE UNIT ARE GIVEN ON THE MANUFACTURER'S LABEL.**



ANY TAMPERING WITH THE INTERNAL CONNECTIONS IS PROHIBITED AND WILL VOID THE WARRANTY.



INSTALLATION ONLY BY EXPERTS AND ONLY IN ACCORDANCE WITH LOCAL REQUIREMENTS AND NATIONAL ELECTRICAL CODE



**DISCONNECT THE UNIT FROM POWER SUPPLY BEFORE ANY MAINTENANCE OPERATIONS!
ENSURE THAT THE UNIT IS SWITCHED OFF FROM THE SUPPLY MAINS BEFORE REMOVING THE GUARD.**



FOLLOWING THE REGULATIONS STIPULATED HEREIN WILL ENSURE A LONG AND TROUBLE-FREE OPERATION OF THE UNIT



USER'S WARRANTY CLAIMS SHALL BE SUBJECT TO REVIEW ONLY UPON PRESENTATION OF THE UNIT, THE PAYMENT DOCUMENT AND THE USER'S MANUAL WITH THE PURCHASE DATE STAMP



WARNING - TO REDUCE THE RISK OF FIRE, ELECTRIC SHOCK, OR INJURY TO PERSONS, OBSERVE THE FOLLOWING:

-USE THIS UNIT ONLY IN THE MANNER INTENDED BY THE MANUFACTURER. IF YOU HAVE QUESTIONS, CONTACT THE MANUFACTURER.

-BEFORE SERVICING OR CLEANING UNIT, SWITCH POWER OFF AT SERVICE PANEL AND LOCK THE SERVICE DISCONNECT MEANS TO PREVENT POWER FROM BEING SWITCHED ON ACCIDENTALLY. WHEN THE SERVICE DISCONNECTING MEANS CANNOT BE LOCKED, SECURELY FASTEN A PROMINENT WARNING DEVICE, SUCH AS A TAG, TO THE SERVICE PANEL



FOR GENERAL VENTILATING USE ONLY. DO NOT USE TO EXHAUST HAZARDOUS OR EXPLOSIVE MATERIALS AND VAPORS.

PURPOSE



CAUTION!

FOR GENERAL VENTILATING USE ONLY.

DO NOT USE TO EXHAUST HAZARDOUS OR EXPLOSIVE MATERIALS AND VAPORS AS WELL AS FLAMMABLE MIXTURES, EVAPORATION OF CHEMICALS, STICKY SUBSTANCES, FIBROUS MATERIALS, COARSE DUST, SOOT AND OIL PARTICLES OR ENVIRONMENTS FAVOURABLE FOR THE FORMATION OF HAZARDOUS SUBSTANCES (TOXIC SUBSTANCES, DUST, PATHOGENIC GERMS).

**FOR USE IN NON FIRE RATED INSTALLATIONS ONLY.
FOR USE IN ONE- AND TWO-FAMILY DWELLINGS ONLY.**

The unit is designed to ensure continuous mechanical air exchange in houses, offices, hotels, cafes, conference halls, and other utility and public spaces as well as to recover the heat energy contained in the air extracted from the premises to warm up the filtered stream of intake air.

The unit is not intended for organizing ventilation in swimming pools, saunas, greenhouses, summer gardens, and other spaces with high humidity.

Due to the ability to save heating energy by means of energy recovery, the unit is an important element of energy-efficient premises.

The unit is a component part and is not designed for stand-alone operation. It is rated for continuous operation.

Transported air must not contain any flammable or explosive mixtures, evaporation of chemicals, sticky substances, fibrous materials, coarse dust, soot and oil particles or environments favourable for the formation of hazardous substances (toxic substances, dust, pathogenic germs).

DELIVERY SET

Name	Number
Air handling unit	1 pc.
User's manual	1 pc.
Control panel*	1 pc.
Packing box	1 pc.

*The control panel is not included in the delivery set of units equipped with an A21 controller.

DESIGNATION KEY

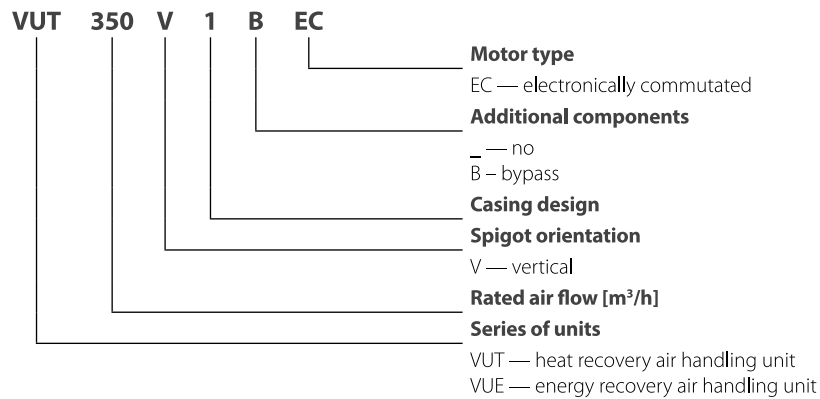

TECHNICAL DATA

The unit is designed for indoor application with the ambient temperature ranging from + 33,8 °F up to +104 °F and relative humidity up to 60 % without condensation. In cold, damp rooms, there is a possibility of freezing or condensation inside and outside the casing.

In order to prevent condensation on the internal walls of the unit, it is necessary that the surface temperature of the casing is 1-2 °F above the dew point temperature of the transported air.

The unit should be operated continuously, and in cases where ventilation is not necessary, reduce the air flow of the fans to a minimum (20%). This will ensure a favorable indoor climate and reduce the amount of condensation inside the unit, which can damage electronic components. Never use the unit for dehumidification, for example, of new buildings.

The unit is rated as a Class I electrical appliance.

Hazardous parts access and water ingress protection rating:

IP20 for the unit connected to the air ducts.

IP44 for the unit motors.

The unit design is constantly being improved, thus some models may be slightly different from those described in this manual.

MODEL	VUT 160 V EC	VUE 160 V EC	VUT 160 VB EC	VUE 160 VB EC	VUT 160 V1 EC	VUE 160 V1 EC	VUT 160 V1B EC	VUE 160 V1B EC	VUT 350 V1B EC	VUE 350 V1B EC	VUT 350 VB EC	VUE 350 VB EC	VUT 550 VB EC	VUE 550 VB EC
Supply voltage [V/50 (60) Hz]	1 ~ 220-240													
Maximum fan power [W]	57				169				178				350	
Maximum unit current (without a heater) [A]	0.5				1.3				1.4				2,4	
Maximum air flow [m³/h]	200				420				450				692	
RPM [min ⁻¹]	3770				3200				2860					
Sound pressure level at 3 m distance [dBA]	24				22				28				38	
Transported air temperature [°F]	+13...+104													
Casing material	Painted steel													
Insulation, mineral wool [inch]	13/16"				1 9/16"									
Filtering class of the extract filter	G4													
Filtering class of the supply filter	F7 (optionally G4)													
Connected air duct diameter [inch]	4 15/16"				6 5/16"				7 7/8"					
Weight [lbs]	75		79		93		97		126		141		181	
Heat recovery efficiency [%]	85-93	76-92	85-93	76-92	85-93	76-92	85-93	76-92	85-92	73-91	85-92	73-91	84-92	73-91
Heat exchanger type	Counter-flow													
Heat exchanger material	Polystyrene	Enthalpy membrane	Polystyrene	Enthalpy membrane	Polystyrene	Enthalpy membrane	Polystyrene	Enthalpy membrane	Polystyrene	Enthalpy membrane	Polystyrene	Enthalpy membrane	Polystyrene	Enthalpy membrane
SEC class	A+	A	A+	A	A+	A	A+	A	A+	A	A+	A	A+	A

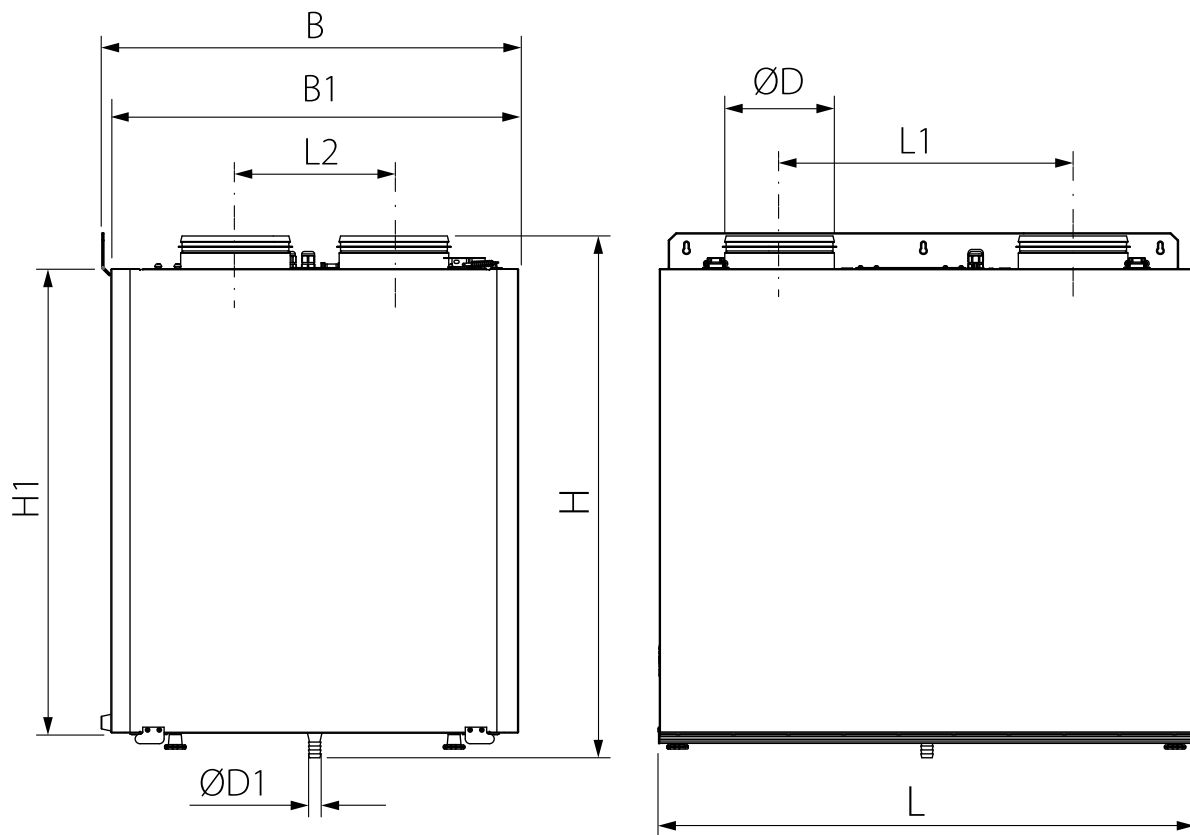

Model	Dimensions [inch]								
	Ø D	Ø D1	B	B1	H	H1	L	L1	L2
VUT/VUE 160 V EC	4 15/16"	11/16"	13 3/8"	13"	26 3/16"	21 5/8"	23 5/8"	15 1/4"	5 5/8"
VUT/VUE 160 V1 EC	4 15/16"	11/16"	14 15/16"	14 9/16"	27 3/16"	23 1/4"	25 3/16"	15 1/4"	5 5/8"
VUT/VUE 160 VB EC	4 15/16"	11/16"	13 3/8"	13"	26 3/16"	22 13/16"	23 5/8"	15 1/4"	5 5/8"
VUT/VUE 160 V1B EC	4 15/16"	11/16"	14 15/16"	14 9/16"	27 15/16"	24 7/16"	25 3/16"	15 1/4"	5 5/8"
VUT/VUE 350 VB EC	6 5/16"	11/16"	23 5/8"	22 15/16"	29 15/16"	26 9/16"	28 3/4"	16 3/4"	9 1/16"
VUT/VUE 350 V1B EC	6 5/16"	11/16"	18 7/8"	18 1/2"	29 15/16"	26 9/16"	28 3/4"	16 3/4"	7 7/8"
VUT/VUE 550 VB EC	7 7/8"	11/16"	28 3/4"	28 3/8"	29 15/16"	26 9/16"	32 3/8"	19 5/8"	11 5/16"

DESIGN AND OPERATING PRINCIPLE

The unit has the following operating principle: warm stale extract air from the room flows into the unit where it is filtered by the extract filter, then air flows through the heat exchanger and is exhausted outside by the extract fan. Cold fresh air from the outside flows into the unit, where it is cleaned by the supply filter. Then the air flows through the heat exchanger and is directed to the room with the supply fan. Heat energy of warm extract air is transferred to clean intake fresh air from the outside and warms it up. The air flows are fully separated while flowing through the heat exchanger. Heat recovery minimizes heat losses, which reduces the cost of space heating in the cold season.

UNIT DESIGN

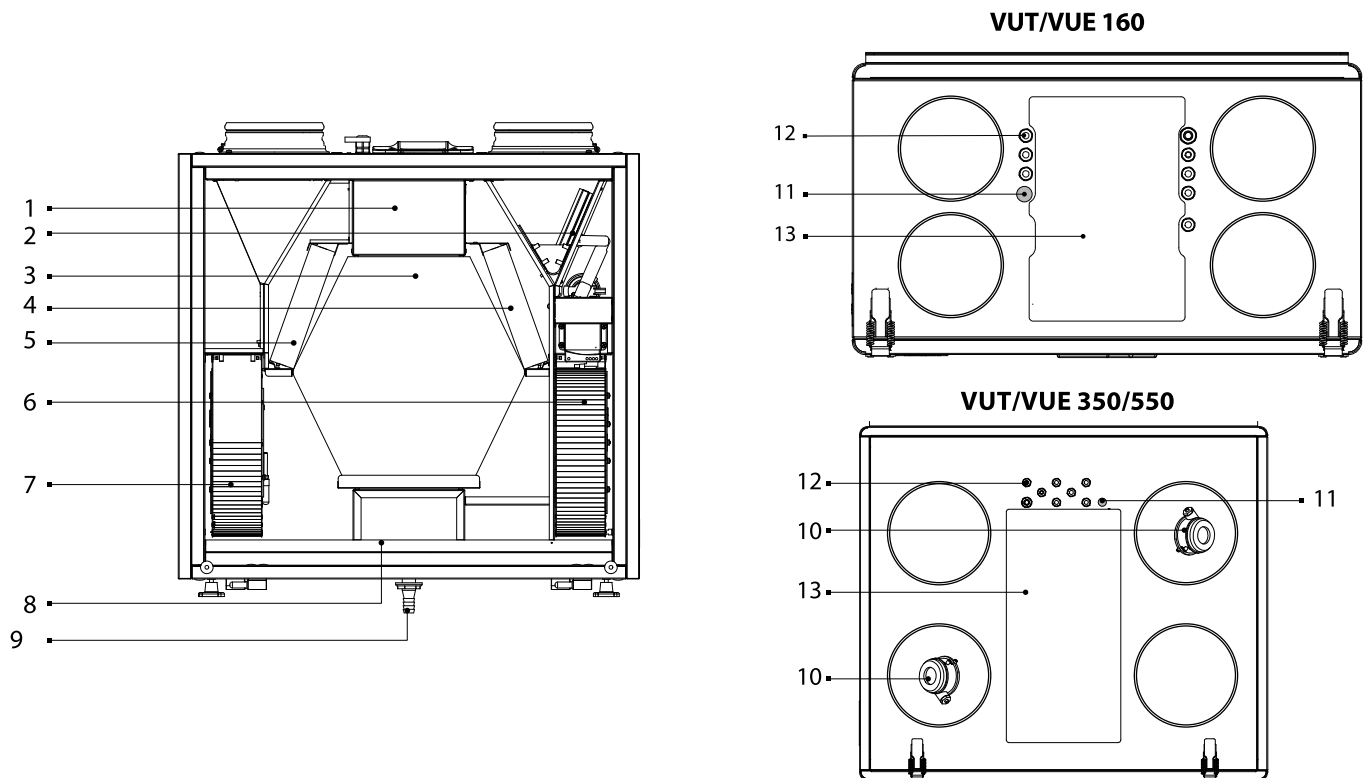

1 – control unit; **2** – bypass damper (except for VUT/VUE 160 V(1) EC models); **3** – counter-flow heat exchanger; **4** – extract filter; **5** – supply filter; **6** – supply fan; **7** – extract fan; **8** – drain pan; **9** – drain pipe; **10** – differential pressure switch (only for VUT/VUE 550 A21 models); **11** – SETUP MODE button (for the units with A21 automation); **12** – cable glands; **13** – control unit lid.

The air handling unit is equipped with a hinged front service panel for repair and maintenance operations. The removable service panel design enables to change the service side location. The control unit is accessible for installation and wiring operations through the inspection door on top of the unit. The power cable and ground cable are connected to the control unit via the cable glands.

The bypass damper is open or closed depending on operation mode of the unit.

The VUT/VUE 550 VB EC units are equipped with differential pressure switches for filter contamination control. Access to the pressure switches is provided through the inlet and outlet spigots.

The difference between the supply and extract air flow temperature leads to condensate generation in the VUT 160/350/550 V(1)B EC units. Condensate is collected in the drain pan and is removed outside through the drain pipe.

The VUE 160/350/550 V(1)B EC units are equipped with a heat exchanger with an enthalpy membrane and do not require condensate drainage.

Accessories for the unit are available on a separate order.

- **Humidity sensor.** The **HV2** sensor in the VUT/VUE 160/350/550 V(1)(B) EC A21 models is connected to the controller. In the VUT/VUE 160/350/550 V(1)(B) EC A14 models, the **HV2** sensor is connected to the terminal block. The **HR-S** sensor is connected to the controller. The unit with an installed humidity sensor maintains a set indoor humidity point. As the extract air humidity rises above the set point, the system automatically switches to the maximum speed. As the humidity drops down below the set point the unit returns to the previous mode.
- **CO₂ sensor** (connected to the controller). Designed for indoor carbon dioxide concentration measurement and respective air capacity regulation through the control output signal to the fan. Ventilation performance control according to current CO₂ levels is an effective way to reduce energy consumption of a building.
- **VOC sensor** (connected to the controller). Qualitative assessment of air saturation with contaminants (cigarette smoke, exhaled air, solvent and detergent vapours). The sensor sensitivity can be adjusted with regards to the expected maximum level of air pollution. Enables on-demand ventilation which results in considerable energy savings as air is exchanged only upon reaching the preset level of pollution.

- **NKP duct preheater** (for the VUT/VUE 160/350/550 V(1) (B) EC A21 units). The heater maintains the duct air temperature at a point that prevents the heat exchanger freezing. Heater installation and connection to the unit are described in the heater user's manual.
- **NKD duct reheater** (for the VUT/VUE 160/350/550 V(1) (B) EC A21 units). The heater maintains a room temperature set by the temperature sensor. Heater installation and connection to the unit are described in the heater user's manual.

UNIT OPERATION MODES

Heat Recovery mode

Warm extract air from the room flows into the unit and is cleaned in the extract filter. Then the air is moved through the heat exchangers and is exhausted outside with the extract fan. Cold fresh air from outside flows into the unit, where it is cleaned in the supply filter. Then the air flows through the heat exchanger and is directed to the room with the supply fan.

Heat is exchanged between the intake and extract air in the heat exchanger. The air flows are fully separated while flowing through the heat exchanger. Heat recovery minimizes heat losses, which reduces the cost of space heating in the cold season.

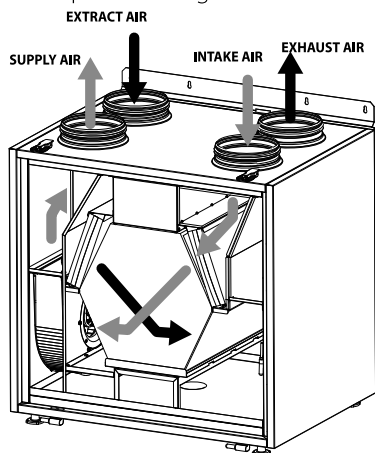

Service side view

Summer Cooling mode

The bypass damper is opened, the extract air that is removed from the premises is routed along the bypass duct and does not come in contact with the heat exchanger. The temperature of the air is not changed after passing through the heat exchanger.

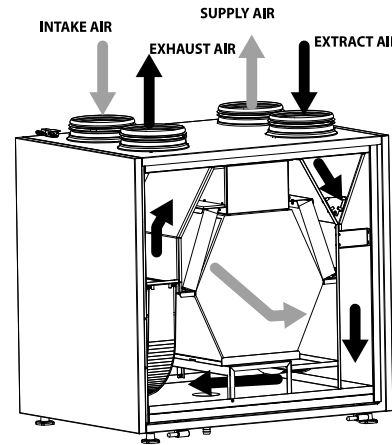

Back side view

Heat exchanger freeze protection (frost danger appears when the extract air temperature downstream of the heat exchanger is lower than +41 °F and intake air temperature upstream of the heat exchanger is lower than +26,6 °F for units with preheating and +37,4 °F for units without preheating).

In case of freezing danger, the supply fan is turned off in the VUT/VUE 160/350/550 V(1)(B) EC A14 units.

When the temperature increases, the unit returns to the previous operation mode. The VUT/VUE 160/350/550 V(1)(B) EC A21 units have two freeze protection modes:

- periodically the supply fan is turned off
- with the electric preheater (if the unit is equipped with a duct preheater)

Mode selection and settings are described in the A21 control system user's manual.

Warning! The heat exchanger freeze protection mode using bypass is not available.

INSTALLATION AND SET-UP

READ THE USER'S MANUAL BEFORE INSTALLING THE UNIT.

AFTER INSTALLING THE UNIT, LOCK THE LATCH TO PREVENT ACCIDENTAL OPENING OF THE COVER.

SERVICE SIDE CHANGE

The unit design allows changing the service side.

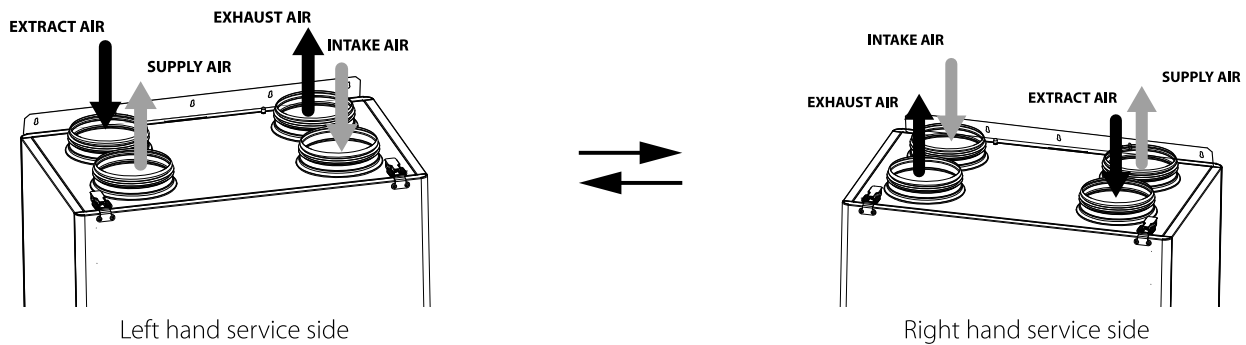

Remove the hinge stopper.

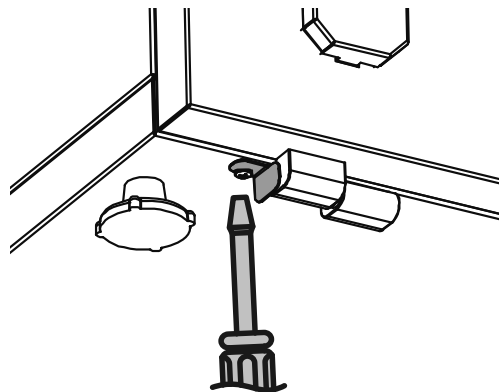

Release the latches, disconnect the ground cable and remove the service panel.

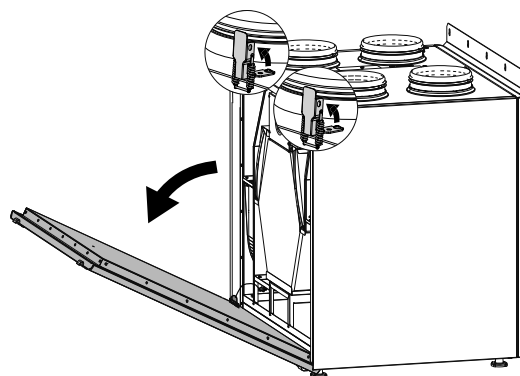

Remove the latches and move them to the opposite side. Remove the back panel by undoing the three screws hidden under plastic plugs.

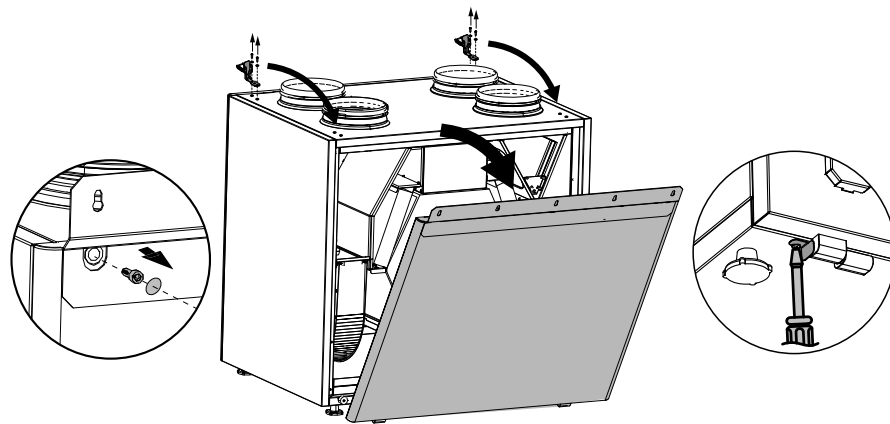

Install the service panel on the opposite side, connect it with a ground wire. Install the back cover.
 Attach the hinge stopper.

HUMIDITY SENSOR MOUNTING

The humidity sensor is not included in the delivery set and must be purchased separately.
 The sensor is installed in the exhaust air duct upstream of the heat exchanger.
 For ease of installation, it is recommended to remove the rear panel of the unit (see the figure above).

VUT/VUE 160

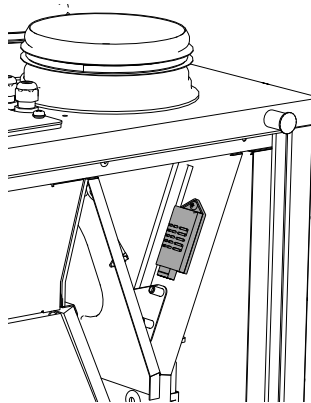

VUT/VUE 350/550

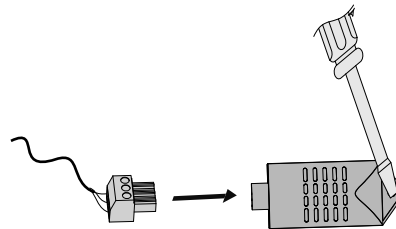
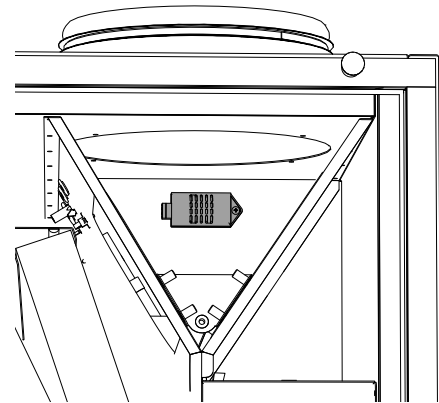

Fasten the sensor with the screw on the threaded rivet. Connect the sensor connector to the connector with the cable from the control unit.

UNIT INSTALLATION

To get the best performance of the unit and to minimize turbulence-induced air pressure losses, connect the straight air duct section to the spigots on both sides of the unit while installing.

Minimum straight air duct length:

- equal to 1 air duct diameter on the intake side
- equal to 3 air duct diameter on the outlet side

Push the air ducts onto the flanges of the unit until stop. Flexible ducts must be fixed rigidly with a metal worming clamp.

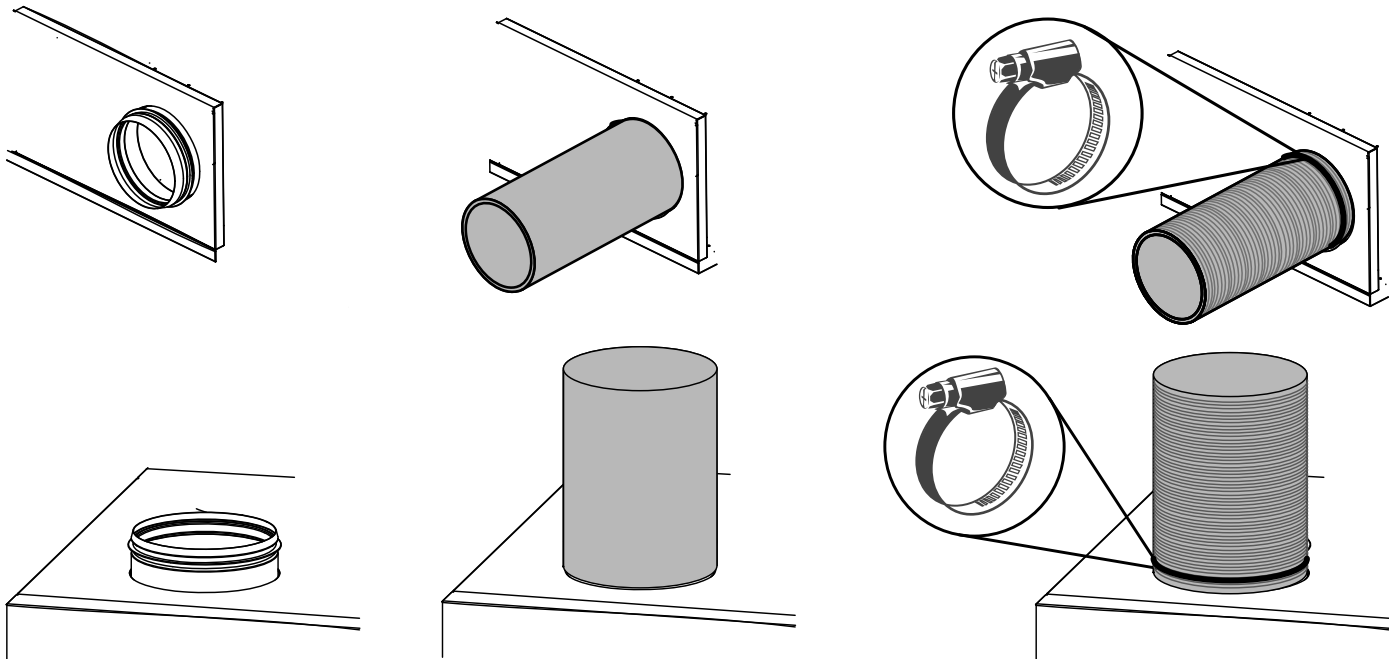

If the air ducts are too short or not connected, protect the unit parts from ingress of foreign objects. To prevent uncontrollable access to the fans, the spigots may be covered with a protecting grille or other protecting device with mesh width not more than 1/2".

When selecting the unit mounting position, enable free excess to the service panel for maintenance and service operations.

The unit should be mounted strictly horizontally in the longitudinal and transverse planes. In case of non-compliance, unit's casing distortion and operation disturbance will occur.

Unit wall mounting

Dowels for wall mounting are not included in the delivery set and should be ordered separately.

While choosing dowels consider the material of the mounting surface as well as the weigh of the unit, refer to the "Technical data" section. Dowels for unit mounting should be selected by the installation specialist.

Install the dowels in the wall. Install the screws. Suspend the unit. Achieve a strictly vertical position of the unit by rotating the adjustable stop (1).

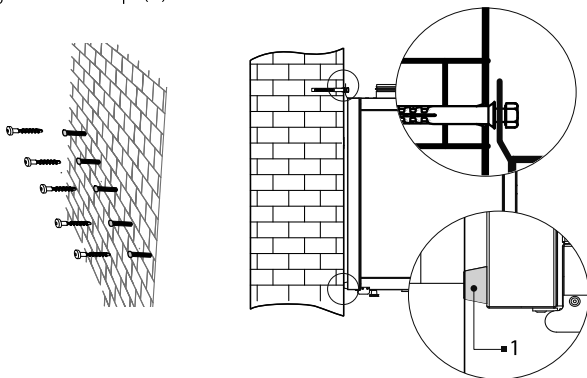

Unit floor mounting

Install the unit on the pre-mounted floor supports, minimum 5 7/8" height, to ensure sufficient access for the drain pipe connection to the U-trap and for condensate drain system installation.

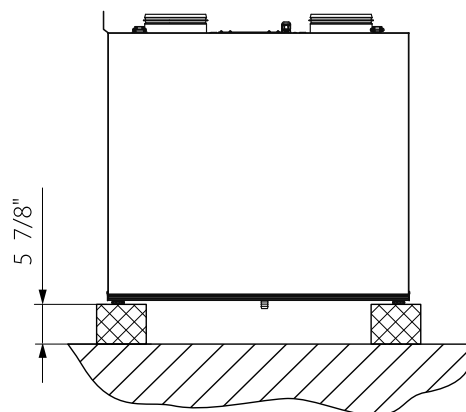

CONDENSATE DRAINAGE

Condensate drainage is required for the VUT 160/350/550 V(1)(B) EC unit series.

The hole for the drain pipe is at the bottom of the unit. Remove the plug from the hole. Open the service panel and remove the plug in the drain pan. Install the drain pipe from the delivery set into the hole, then connect the drain pipe to the sewage system using the SFK 20x32 U-trap kit (available upon separate order). Make sure the U-trap is always filled with water. The pipe slope downwards must be at least 3°.

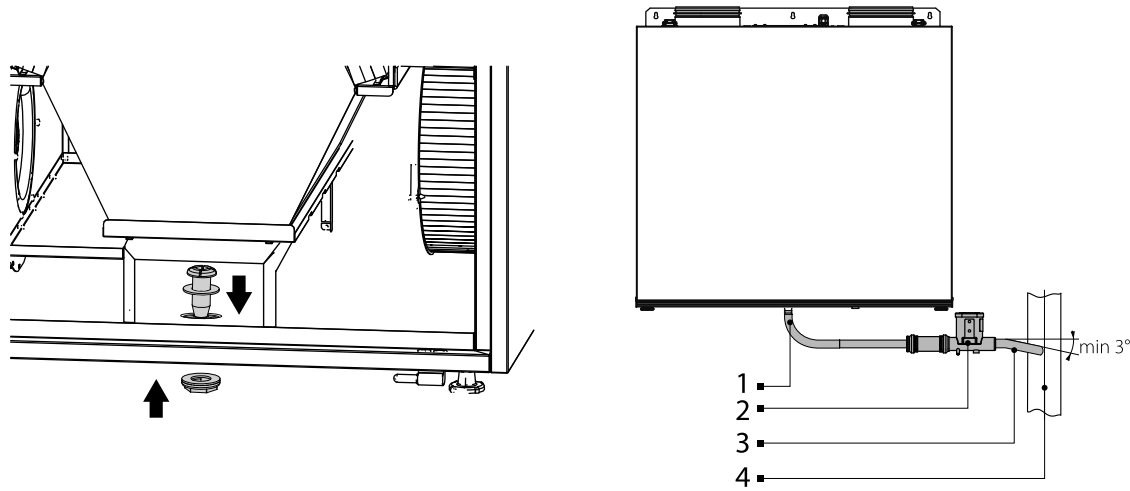

1 – drain pipe; 2 – U-trap; 3 – drain hose; 4 – sewage system

CONNECTION TO POWER MAINS

POWER OFF THE POWER SUPPLY PRIOR TO ANY OPERATIONS WITH THE UNIT.



THE UNIT MUST BE CONNECTED TO POWER SUPPLY BY A QUALIFIED ELECTRICIAN.

THE RATED ELECTRICAL PARAMETERS OF THE UNIT ARE GIVEN ON THE MANUFACTURER'S LABEL.



ANY TAMPERING WITH THE INTERNAL CONNECTIONS IS PROHIBITED AND WILL VOID THE WARRANTY.

For accessing the terminal block and the controller undo the screws of the terminal box cover and remove it.

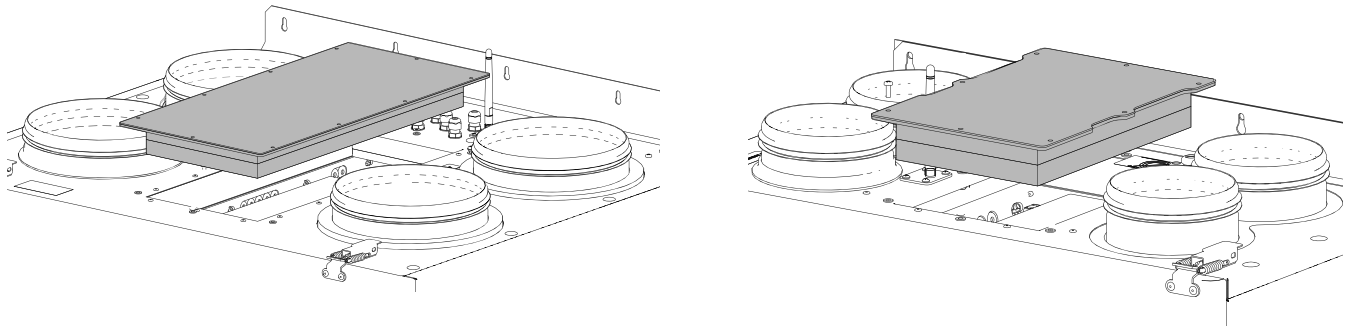

Route the cables to the control unit through the cable glands in the unit. Carry out the electrical connections as shown in the wiring diagram.

EXTERNAL WIRING DIAGRAM FOR THE VUT/VUE 160/350/550 V(1)(B) EC A14 UNITS

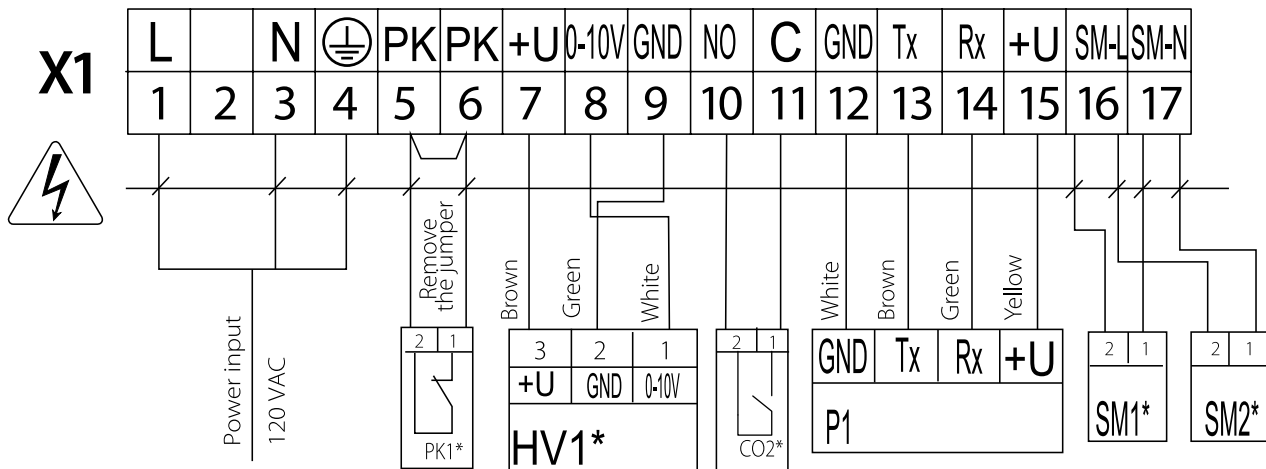

Designation	Name	Model	Wire**
SM1*	Supply air damper actuator		2 x 0.75 mm ² (18 AWG)
SM2*	Extract air damper actuator		2 x 0.75 mm ² (18 AWG)
PK1*	Contact from fire alarm panel	NC	2 x 0.75 mm ² (18 AWG)
CO2*	CO ₂ sensor	NO	2 x 0.75 mm ² (18 AWG)
HV1*	Humidity sensor		3 x 0.75 mm ² (18 AWG)
P1	External control panel		4 x 0.25 mm ² (24 AWG)

*Is not included in the delivery set.



EXTERNAL CONNECTIONS DIAGRAM FOR THE VUT/VUE 160 V(1) B EC A21 UNITS

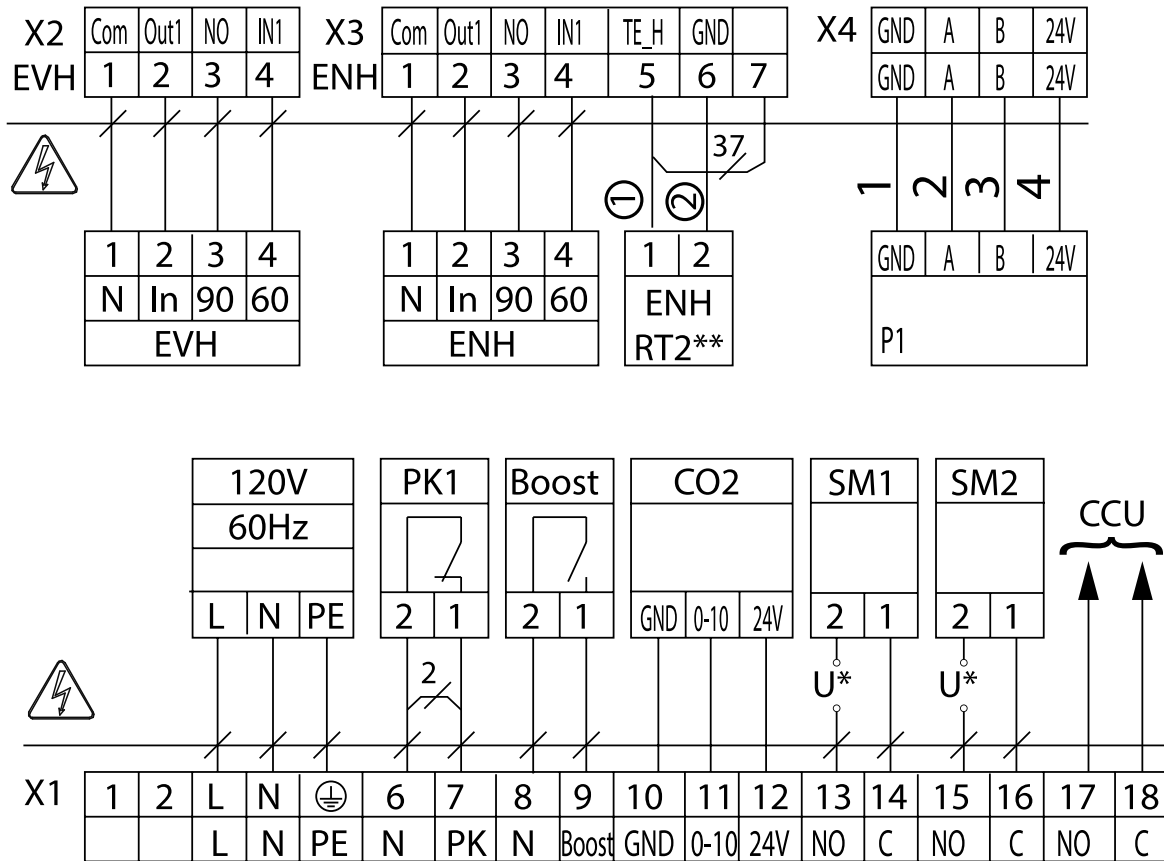

① — brown; ② — white.

Designation	Name	Model	Wire type	Note
SM1*	Supply air damper actuator	NO	2 x 0.75 mm ² (18 AWG)	3 A, 30VDC/~250 AC
SM2*	Extract air damper actuator	NO	2 x 0.75 mm ² (18 AWG)	3 A, 30VDC/~250 AC
PK1	Contact from fire alarm panel	NC	2 x 0.75 mm ² (18 AWG)	Remove the jumper 2
CCU	Cooler control	NO	2 x 0.75 mm ² (18 AWG)	3 A, 30VDC/~250 AC
P1	External control panel		4 x 0.5 mm ² (20 AWG)	
Boost	Boost On/Off contacts of the Boost mode	NO	2 x 0.75 mm ² (18 AWG)	
CO2	External CO ₂ sensor		3 x 0.25 mm ² (24 AWG)	
EVH	Duct heater (for preheating)		4 x 0.5 mm ² (20 AWG)	
ENH	Duct heater (for reheating)		4 x 0.5 mm ² (20 AWG)	
ENH RT2**	Duct temperature sensor		2 x 0.25 mm ² (24 AWG)	Remove the jumper 37

*The supply voltage U of the SM1, SM2 external dampers is selected depending on the type of dampers.

**Part of ENH.



EXTERNAL CONNECTIONS DIAGRAM FOR THE VUT/VUE 350/550 V(1) B EC A21 UNITS

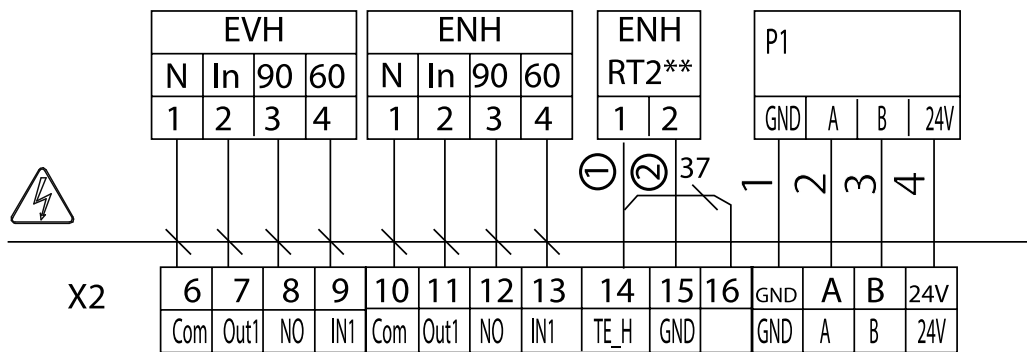
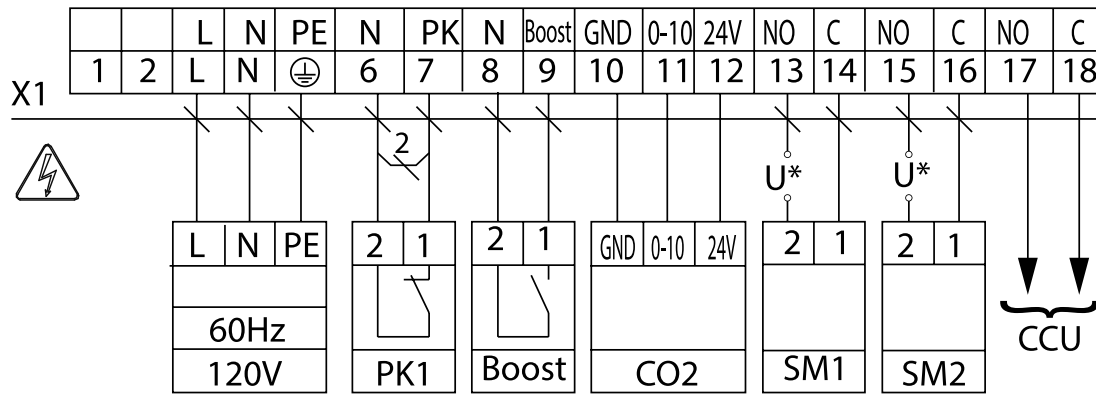

① — brown; ② — white.

Designation	Name	Model	Wire type	Note
SM1*	Supply air damper actuator	NO	2 x 0.75 mm ² (18 AWG)	3 A, 30VDC/~250 AC
SM2*	Extract air damper actuator	NO	2 x 0.75 mm ² (18 AWG)	3 A, 30VDC/~250 AC
PK1	Contact from fire alarm panel	NC	2 x 0.75 mm ² (18 AWG)	Remove the jumper 2
CCU	Cooler control	NO	2 x 0.75 mm ² (18 AWG)	3 A, 30VDC/~250 AC
P1	External control panel		4 x 0.5 mm ² (20 AWG)	
Boost	Boost On/Off contacts of the Boost mode	NO	2 x 0.75 mm ² (18 AWG)	
CO2	External CO ₂ sensor		3 x 0.25 mm ² (24 AWG)	
EVH	Duct heater (for preheating)		4 x 0.5 mm ² (20 AWG)	
ENH	Duct heater (for reheating)		4 x 0.5 mm ² (20 AWG)	
ENH RT2**	Duct temperature sensor		2 x 0.25 mm ² (24 AWG)	Remove the jumper 37

*The supply voltage U of the SM1, SM2 external dampers is selected depending on the type of dampers.

**Part of ENH.



TECHNICAL MAINTENANCE

Maintenance operations of the unit are required 3-4 times per year. They include general cleaning of the unit and the following operations:

1. Filter maintenance (3-4 times per year).

Dirty filters increase air resistance in the system and reduce supply air volume. The filters require cleaning not less than 3-4 times per year. Clean the filter with a vacuum cleaner or replace it with a new one. For new filters contact the Seller.

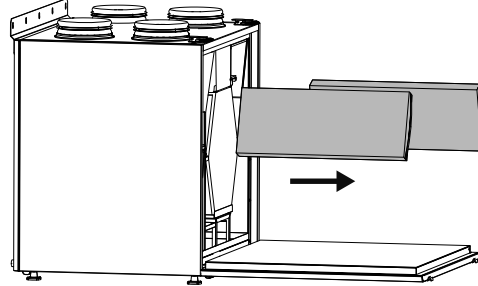

2. Heat exchanger maintenance (once per year).

Some dust may accumulate on the heat exchanger even in case of regular maintenance of the filters. To maintain the high heat recovery efficiency, regular cleaning is required. To clean the heat exchanger, remove it from the unit and clean the heat exchanger by using compressed air or a vacuum cleaner. In case of severe contamination, the heat exchanger can be washed with water. After cleaning, re-install the heat exchanger into the unit.

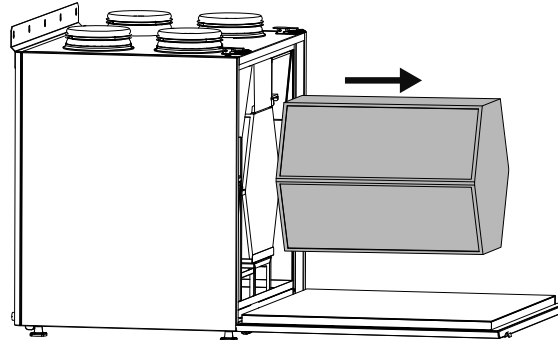

3. Fan maintenance (once per year).

Even in case of regular maintenance of the filters, some dust may accumulate inside the fans and reduce the fan performance and supply air flow. Fans should be cleaned by the service technician.

4. Condensate drainage system maintenance (4 times per year).

The condensate drainage (drain line) may get clogged by dirt and dust particles contained in the exhaust air. Check the drain line operation by filling the drain pan under the unit with water, clean the U-trap and the drain line, if necessary.

5. Supply air flow control (twice per year).

The supply duct grille may get clogged with leaves and other objects reducing the unit performance and supply air delivery. Check the supply grille twice per year and clean it as required.

6. Ductwork system maintenance (once in 5 years).

Even regular fulfilling of all the maintenance operations prescribed above may not completely prevent dirt accumulation in the air ducts, which leads to air pollution and reduces the unit capacity. Duct maintenance means regular cleaning or replacement.



IF UNIDENTIFIED NOISES OR ODOURS SHOULD ARISE AND IN CASE OF DEFORMATION OF ELEMENTS, VIBRATION, TERMINATION OF AIR SUPPLY/EXTRACTION OR REDUCED SYSTEM PERFORMANCE, IMMEDIATELY DISCONNECT THE UNIT FROM POWER SUPPLY AND CONTACT THE SELLER FOR THE VENTILATION SYSTEM DIAGNOSTICS. DIAGNOSTICS MUST BE CARRIED OUT BY QUALIFIED SPECIALISTS.

POSSIBLE REASONS AND TROUBLESHOOTING

Problem	Possible reasons	Troubleshooting
The fan(s) does not start when the unit is on.	No power supply.	Make sure the power supply line is connected correctly, otherwise troubleshoot the connection error.
	The mode in which the fans are turned off is set.	Change the mode with the help of the control panel.
Low air flow.	Low set fan speed.	Set higher speed.
	The filters and the fans are clogged, the heat exchanger is clogged.	Clean or replace the filters, clean the fans and the heat exchanger.
	Ventilation system elements (air ducts, diffusers, louver shutters, grilles) are clogged, damaged or closed.	Clean or replace the ventilation system elements, such as air ducts, diffusers, louver shutters, grilles.
Cold supply air.	The extract filter is soiled.	Clean or replace the extract filter.
Noise, vibration.	The fan or casing screw connection is loose.	Tighten the screw connection of the fans or the casing.
	No anti-vibration connectors on air duct pipe flanges.	Install anti-vibration connectors.
Water leakage (only for the VUT VB EC units)	The drainage system is soiled, damaged, or installed incorrectly.	Clean the drain line. Check the drain line slope angle. Make sure that the U-trap is filled with water and the drain pipes are frost protected.

If troubleshooting steps have failed, contact the Seller of the product.

In case of faults not described in the table, contact the Seller for further information.

STORAGE AND TRANSPORTATION REGULATIONS

- Store the unit in the manufacturer’s original packaging box in a dry closed ventilated premise with temperature range +41 °...+104 °F and relative humidity up to 70 %.
- Storage environment must not contain aggressive vapors and chemical mixtures provoking corrosion, insulation, and sealing deformation.
- Use suitable hoist machinery for handling and storage operations to prevent possible damage to the unit.
- Follow the handling requirements applicable for the particular type of cargo.
- The unit can be carried in the original packaging by any mode of transport provided proper protection against precipitation and mechanical damage. The unit must be transported only in the working position.
- Avoid sharp blows, scratches, or rough handling during loading and unloading.
- Prior to the initial power-up after transportation at low temperatures, allow the unit to warm up at operating temperature for at least 3-4 hours.

MANUFACTURER'S WARRANTY

Production meets standard operating requirements in the USA and Canada.

Vents US warrants to the original purchaser of the unit that it will be free from defects in materials or workmanship for a period of 24 months from the date of original purchase. The Vents US warrants to the original purchaser of the unit that the integrated control unit will be free from defects in materials and workmanship for a period of 24 months from the date of original purchase.

THERE ARE NO OTHER WARRANTIES, EXPRESS OR IMPLIED, INCLUDING, BUT NOT LIMITED TO, IMPLIED WARRANTIES OF MERCHANTABILITY OR FITNESS FOR A PARTICULAR PURPOSE.

During the stated warranty period, Vents US will, at its option, repair or replace, without charge, any product or part which is found to be defective under normal use and service. This warranty does not cover (a) normal maintenance and normal service or (b) any products or parts which have been subject to misuse, negligence, accident, improper maintenance or repair (other than by Vents US), faulty installation or installation contrary to recommended installation instructions. Labor to remove and replace products is not covered. The duration of any implied warranty is limited to the time period specified for the express warranty. Some states do not allow limitations on how long an implied warranty lasts, so the above limitation may not apply to you.

VENTS US OBLIGATION TO REPAIR OR REPLACE, AT VENTS US OPTION, SHALL BE THE PURCHASER'S SOLE AND EXCLUSIVE REMEDY UNDER THIS WARRANTY. VENTS US SHALL NOT BE LIABLE FOR INCIDENTAL, CONSEQUENTIAL OR SPECIAL DAMAGES ARISING OUT OF OR IN CONNECTION WITH PRODUCT USE OR PERFORMANCE.

Some states do not allow the exclusion or limitations of incidental or consequential damages, so the above limitation or exclusion may not apply to you. This warranty gives you specific legal rights, and you may also have other rights which vary from state to state. This warranty supersedes all prior warranties. If proof of sales date is absent, warranty period is calculated from the production date. The unit can be exchanged at the following address:

Vents-US
400 Murray Road, Cincinnati, OH 45217, USA
Tel: 1-888-640-0925, 513-583-5786, Fax: 513-268-4597
E-mail: support@ventsus.com
www.vents-us.com

Please follow guidelines in this manual for product problem-free operation.



**FOLLOWING THE REGULATIONS STIPULATED HEREIN WILL
ENSURE A LONG AND TROUBLE-FREE OPERATION OF THE
UNIT**



**USER'S WARRANTY CLAIMS SHALL BE SUBJECT TO REVIEW
ONLY UPON PRESENTATION OF THE UNIT, THE PAYMENT
DOCUMENT AND THE USER'S MANUAL WITH THE PURCHASE
DATE STAMP**

CERTIFICATE OF ACCEPTANCE

Unit Type	Air handling unit
Model	
Serial Number	
Manufacture Date	
Quality Inspector's Stamp	

SELLER INFORMATION

Seller	
Address	
Phone Number	
E-mail	
Purchase Date	
This is to certify acceptance of the complete unit delivery with the user's manual. The warranty terms are acknowledged and accepted.	
Customer's Signature	

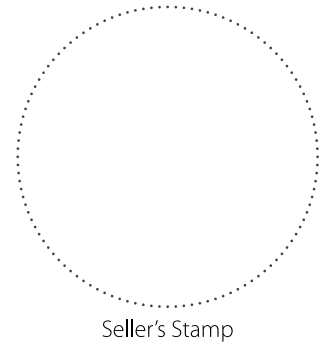

Seller's Stamp

INSTALLATION CERTIFICATE

The _____ unit is installed pursuant to the requirements stated in the present user's manual.	
Company name	
Address	
Phone Number	
Installation Technician's Full Name	
Installation Date:	Signature:
The unit has been installed in accordance with the provisions of all the applicable local and national construction, electrical and technical codes and standards. The unit operates normally as intended by the manufacturer.	
Signature:	

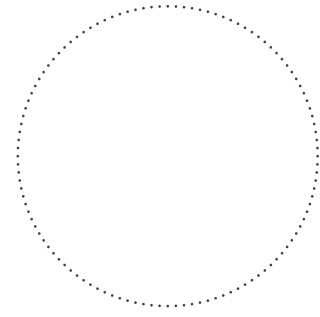

Installation Stamp

WARRANTY CARD

Unit Type	Air handling unit
Model	
Serial Number	
Manufacture Date	
Purchase Date	
Warranty Period	
Seller	

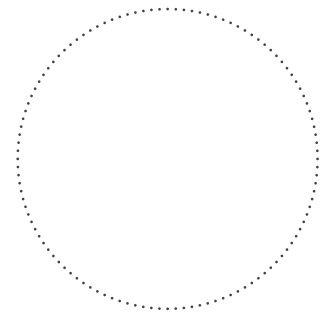

Seller's Stamp



VUSA239EN-01