

Freshbox 100 ERV WiFi



The Freshbox 100 Single Room Series are cutting-edge Ductless systems engineered to significantly improve indoor air quality while optimizing energy efficiency in both residential and small commercial environments. Available in either an ERV or HRV. Wi-Fi enabled.

- Motor type: EC
- Enthalpy heat exchanger
- Bypass: Auto
- Control: Smartphone
- Casing material: Coated steel
- CO2 sensor: Optional
- VOC sensor: Optional
- PM2.5 sensor: Optional
- Temperature sensor: Built-in

	Unit of measurement	Freshbox 100 ERV WiFi		
Connected air duct size	in	4"		
Speed	-	3		
Phases	-	1		
Minimum supply voltage	V	120		
Maximum supply voltage	V	120		
Power supply frequency	Hz	50/60		
Rated power	W	20	29	53
Maximum unit current	A	0.4		
Heat recovery efficiency, max	%	90		

Dimensions

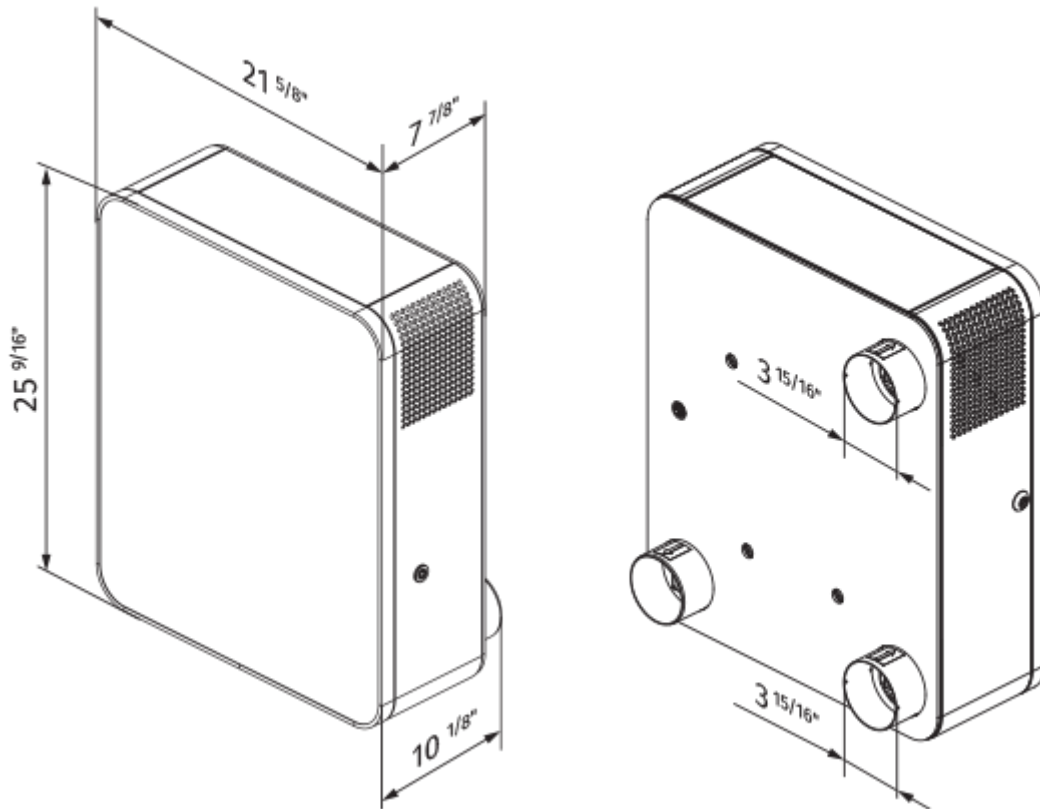

Accessories

Other accessories

Name	Photo	Description
Freshbox 100 Ductless Mounting Kit White		Mounting kit: Two plastic air ducts; Outdoor box; Cardboard template