



### DESCRIPTION

TwinFresh Comfo RA1-50-2 is the unique Single Room Energy Recovery Ventilator. Designed to ensure filtration and supply of fresh air into the room as well as exhaust of stale air with energy regeneration. One TwinFresh unit in ventilation mode can serve rooms up to 500 sq.ft\*.

\*In accordance with ANSI/ASHRAE Standard 62.2-2016

### KEY FEATURES:

- Efficient supply and exhaust single-room ventilation up to 30 CFM.
- Sensible Recovery Efficiency up to 88 %.
- Efficacy 2.14 CFM/W – twice as high as the Energy Star requirements.
- Multifunctional wireless remote control.
- 100 % corrosion proof stainless steel outer hood.
- Air purification with total MERV 5 filters.
- Antibacterial treatment of ERV core and filters.
- Easy mounting and maintenance.
- Frost- and condensate-free.

### MOTOR

DC motor with outstanding low energy demand from 4,50 W. The fan is powered by safe voltage 12 V. The motor has integrated overheating protection and ball bearings for long service life.

### DIMENSIONS

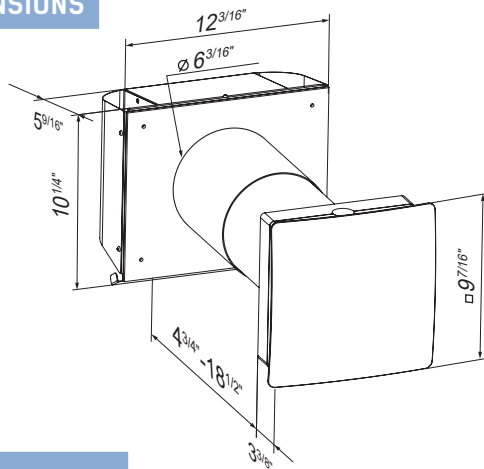

### PERFORMANCE

Model	Speed	Voltage	Power [W]	Current [A]	CFM in ventilation mode	CFM in regeneration mode	RPM	Sones @10 ft.	ARE @32°F	Transported air temp. [°F]
RA1-50-2	1	120 V 60 Hz	4.50	0.045	12	6	610	0.2	88 %	From -4 up to 104
	2		5.00	0.049	19	9	800	0.4		
	3		7.00	0.076	30	15	1450	0.5		

MODEL	QUANTITY	COMMENTS	PROJECT
			location:
			architect:
			engineer:
			contractor:
			submitted by: